

REGULATIONS 2021V.5

REGULATION 1 – BOUNDARIES

- 1.01** Subject to the provisions of this Article • each LGB shall have the right to establish its own boundaries provided that such boundaries do not encroach upon the geographic area of the approved boundaries of another LGB, Club, Association or Team.
- 1.02** Subject to the provisions of this Article •, any Club, Association or Team, which is not a member of an LGB shall have the right to establish its own boundaries provided that such boundaries do not encroach upon the geographic area of the approved boundaries of any LGB, or other Club, Association or Team.
- 1.03** Any LGB, Club, Association or Team which establishes boundaries in accordance with sections 1.01 and 1.02 above shall submit such boundaries to the Board for ratification. In the absence of any extraordinary circumstances or a conflict with the existing approved boundaries or proposed boundaries of any other LGB, Club, Association or Team, the Board shall ratify such boundaries as submitted.
- 1.04** If prior to the ratification of the proposed boundaries the Board becomes aware of any conflict with such proposed boundaries, the Board shall notify in writing each of the party requesting such ratification, and any parties with whom such proposed boundaries conflict.
- 1.05** Upon receipt of any written notice from the Board issued pursuant to section 1.04 above, each of the affected parties shall meet and in good faith attempt to resolve the conflict. If the conflict is resolved between the parties within 30 days of the date of the notice issued by the Board pursuant to section 1.04 or such further period of time mutually agreed to by the conflicting parties, a joint written notice signed by each of the conflicting parties shall be delivered to the Executive Director advising the Board that an agreement has been reached, which notice shall outline the agreed resolution.
- 1.06** If such agreed resolution does not encroach upon the geographic area of the approved boundaries of any LGB, or other Club, Association or Team, then in the absence of any extraordinary circumstances the Board shall approve such boundary and such decision of the Board shall be final and binding upon the conflicting parties delivering the joint written notice.
- 1.07** If the conflicting parties are unable, within thirty days of the date of the notice issued by the Board pursuant to section 1.04 or such further period of time mutually agreed to by the conflicting parties, a joint written notice signed by each of the conflicting parties shall be delivered to the Executive Director advising the Board that no resolution to the conflict could not be reached.
- 1.08** In the event no resolution can be reached by the conflicting parties, each of the conflicting parties shall be entitled to make written submissions to the Board in support of their respective positions. Each of the conflicting parties shall also be entitled to attend and make verbal submissions to the Board at its immediately next succeeding meeting. Once the Board has received and reviewed the written submissions, if any, and heard any verbal submissions made by the conflicting parties, the Board shall then decide the matter on the issue of the proposed boundaries and such decision of the Board shall be final and binding upon the conflicting parties. The Board will take no adverse inference from the failure of a conflicting party to make either written or verbal submissions and

shall make its decision upon the merits of the individual circumstances on a case by case basis.

1.09 If prior to the ratification of the proposed boundaries the Board becomes aware of any extraordinary circumstances with respect to such proposed boundaries, the Board shall notify in writing the party requesting such ratification of the nature of such extraordinary circumstances and advising such party that it has an opportunity to either provide a written submission in support of such request or the opportunity to attend the immediately next succeeding meeting of the Board to provide verbal submissions in support of its request. Once the Board has received and reviewed the written submission, if any, and heard any verbal submissions made by the requesting party, the Board shall then decide the matter on the issue of the proposed boundaries and such decision of the Board shall be final and binding upon the requesting party. The Board will take no adverse inference from the failure of a requesting party to make either written or verbal submissions and shall make its decision upon the merits of the individual circumstances on a case by case basis.

1.10 Any boundary dispute between any Association, Club or Team within an LGB shall in first instance be resolved by the affected LGB in accordance with its own governing documents. Any decision by an LGB with respect to a dispute between any Association, Club or Team within a given LGB may be appealed to the ALA, as any other decision of a Member.

1.11 An Association, Club or Team shall not withdraw from its then approved LGB after January 15 in any calendar year without the approval of the board of the said LGB, such approval may not be unreasonably or arbitrarily withheld as such action has a significant affect upon the boundaries of an LGB. If an Association, Club or Team makes application to withdraw from its then approved LGB and such application is denied by the LGB such decision of the LGB may be appealed to the ALA, as any other decision of a Member

REGULATION 2 – TAMPERING

2.01 No player, or potential player, shall be contacted by anyone connected to a Boundary area outside the players' Boundary area in which the player, or potential player, resides about playing for a team in another Boundary area without first receiving written permission of the President of the Member of the Boundary area in which the player or potential player resides.

2.02 In Major Lacrosse, the Rocky Mountain Lacrosse League may establish its' own regulations in regards to tampering which may be in addition to ALA Regulation 2.01.

REGULATION 3 - PLAYER ELIGIBILITY

General Policy

3.01 All players must be accurately registered in the recognized ALA registration system.

3.02 Players in Minor Box are permitted to register on ONE TEAM per division and level as approved by ALA Executive.

3.03 Players, coaches, and officials are be registered in the ALA online registration system prior to participating in any ALA sanctioned events.

3.04 All Team Alberta Players must be registered with an ALA Member Club in the applicable discipline of lacrosse that the player is trying out for prior to Team Alberta Tryouts.

3.04.1 Team Alberta players who commit to attending the CLA National Competition must full fill this commitment prior to attending a CLA National Competition at an older age division.

REGULATION 4 - REGISTRATION

4.01 Except as hereinafter provided, no player shall be registered as a member of, or compete for, a team in any ALA match who has not been a bona fide resident within that team's Boundary area as established by the ALA or Local Governing Body since April 1st of the playing season.

4.02 A minor players residence is the address of the parent/guardian with custody of player as of April 1 in the competition year. Addresses while at school are not considered permanent residences.

4.03 If there is no team in the player's division within the Boundary area in which the player resides, or if the player does not reside within a recognized Boundary area, player's must play in the Boundary area which is nearest by ordinary travel, which has a team registered in his/her Division. A player may not establish residency for the principal purpose of playing or practicing Lacrosse.

4.04 The Zones of the ALA are as per the Alberta Sport Zones. The Boundary areas of a Local Governing Body are those that are established by that Local Governing Body. Club Boundaries are those established by its' Local Governing Body.

4.05 If a player wishes to play on a team outside their Boundary area and if both Clubs (the one releasing and the one receiving the player) agree to the release, then the player may play for the team outside their Boundary area. If the player's resident Boundary area team does not agree, the release request must go to the requesting player's Local Governing Body or, in the case where there is no Local Governing Body, then to the ALA Director of Administration whose decision may be appealed to the Discipline/Appeals Committee. The Discipline/Appeal Committee's decision will be final and binding. At both levels, the request and submissions of the two (2) Clubs, if any, shall be in writing and there shall be no hearing. The player and the Clubs shall be provided with copies of the written submissions and shall have the opportunity to respond in writing. There shall be no appeal. A decision will be made within seven (7) days of receipt of written request.

4.06 The form of release shall be as per ALA Electronic Transfer in the ALA Registration System and unless specifically stated to be otherwise will be effective for one season only. A copy of all releases must be sent to the ALA Office.

4.07 If a player changes residence from one Boundary area to another Boundary area, no release from the player's former Club in the Zone is necessary and the player shall, unless released, play for a team in the Boundary area in which they reside pursuant to Regulation 4.01 and 4.02.

4.08 In Major Lacrosse, the Rocky Mountain Lacrosse League may establish its' own residency requirement which may differ from the above.

REGULATION 5 – COMPETITION

5.01 No team registered with the ALA shall participate in any competition in Canada involving persons who are not registered with Members of the CLA or participate in tournaments or other competitions that are not sanctioned by a Member of the CLA.

5.02 Player Registration Information will not be accepted from any Team or Association until membership requirements have been met and the Association or Team is recorded in the Register of Members.

5.03 Within the ALA the following are the approved Divisions or age categories:

5.03.1 **Box Lacrosse**

- 1) **Recreational Lacrosse** is open to all ages of players for recreational lacrosse as per 5.03.5.
- 2) **Masters Registration** is open to players for recreational lacrosse.
- 3) **Senior Registration** is open to players 22 years of age and over in the year in which they wish to compete.
- 4) **Junior Registration** is open to players who are under 22 years of age and minimum 17 years of age on December 31 in the year in which they wish to compete.
- 5) **Post 16U Registration** is open to players who are under 19 years of age and minimum 17 years of age on December 31 in the year in which they wish to compete may participate in recreational play within their local governing body
- 6) **16U Registration** is open to players who are under 17 years of age and minimum 15 years of age on December 31 in the year in which they wish to compete.
- 7) **14U Registration** is open to players who are under 15 years of age and minimum 13 years of age on December 31 in the year in which they wish to compete.
- 8) **12U Registration** is open to players who are under 13 years of age and minimum 11 years of age on December 31 in the year in which they wish to compete.
- 9) **10U Registration** is open to players who are under 11 years of age and minimum 9 years of age on December 31 in the year in which they wish to compete.
- 10) **8U Registration** is open to players who are under 9 years of age and minimum 6 years of age on December 31 in the year in which they wish to compete. 8U play shall concentrate on the development of players' skills and sportsmanship and shall be non-competitive.
- 11) **6U Registration** is open to players who are under 6 years of age on December 31 in the year in which they wish to compete. 6U shall concentrate on the development of players' skills and sportsmanship and shall be non-competitive.

Note –6U minimum age is at discretion of the club.

5.03.2

Men's Field Lacrosse

- 1) **Recreational Lacrosse** is open to all ages of players for recreational lacrosse as per 5.03.5.
- 2) **Masters Registration** is open to players for recreational lacrosse.
- 3) **Senior Registration** is open to players 20 years of age and over in the year they wish to compete.
- 4) **U19** is open to players who are under 20 years of age and minimum 17 years of age on December 31 in the year in which they wish to compete.
- 5) **U16 Registration** is open to players who are under 17 years of age and minimum 15 years of age on December 31 in the year in which they wish to compete.
- 6) **U14 Registration** is open to players who are under 15 years of age and minimum 13 years of age on December 31 in the year in which they wish to compete.
- 7) **U12 Registration** is open to players who are under 13 years of age and minimum 11 years of age on December 31 in the year in which they wish to compete.
- 8) **U10 Registration** is open to players who are under 11 years of age and minimum 9 years of age on December 31 in the year in which they wish to compete.
- 9) **U8 Registration** is open to players who are under 9 years of age and minimum 6 years of age on December 31 in the year in which they wish to compete. U8 play shall concentrate on the development of players' skills and sportsmanship and shall be non-competitive.
- 10) **U6 Registration** is open to players who are under 6 years of age on December 31 in the year in which they wish to compete. U6 play shall concentrate on the development of players' skills and sportsmanship and shall be non-competitive.

Note – U6 minimum age is at discretion of the club.

5.03.3

Women's Field Lacrosse

- 1) **Recreational Lacrosse** is open to all ages of players for recreational lacrosse as per 5.03.5
- 2) **Masters Registration** is open to players for recreational lacrosse.
- 3) **Senior Registration** is open to players 20 years of age and over in the year they wish to compete.
- 4) **Junior Registration (U19)** is open to players who are under 20 years of age and minimum 16 years of age on December 31 in the year in which they wish to compete.
- 5) **U15 Registration** is open to players who are under 16 years of age and minimum 13 years of age on December 31 in the year in which they wish to compete.
- 6) **U12 Registration** is open to players who are under 13 years of age and minimum 9 years of age on December 31 in the year in which they wish to compete.

- 7) **U8 Registration** is open to players who are under 9 years of age and minimum 5 years of age on December 31 in the year in which they wish to compete. U8 play shall concentrate on the development of players' skills and sportsmanship and shall be non-competitive

5.03.4 **School Field Lacrosse**

- 1) **High School** is open to players who are registered in Grade 12 or under in the year in which they wish to compete.
2) **Junior High School** is open to players who are registered in Grade 9 or under the year in which they wish to compete.

5.03.5 **Recreational Lacrosse**

Recreation lacrosse is aimed at areas without substantial registration numbers, low income individuals, New Canadians, Indigenous people, minority groups and new players who do not wish to play competitively.

5.03.5.1 All participants must be duly registered with the ALA.

5.03.5.2 Recreational lacrosse is a weekly non-competitive drop in program.

5.03.5.3 Recreational lacrosse is co-ed and can be organized by age divisions or by like skill groups.

5.03.5.4 A Community Development Trained coach must be present at all sessions.

5.03.5.5 On floor coaches must have CAC coach training.

5.03.5.6 Required equipment is CLA helmet and facemask, gloves, and appropriate footwear. A soft ball may be used in recreational lacrosse

5.03.5.7 Recreational lacrosse will run a minimum of one hour sessions. The first half hour is skills and drills. The second half hour will be scrimmage controlled by the Community Development Trained coach. Goalies are not required.

5.04 **Exceptions to Registration in Competition Age Groups**

Any exception for any individual player to these regulations, 5.03.1, 5.03.2, 5.03.3 and 5.03.4 must be submitted for approval to the Local Governing Body or the ALA, if there is no Local Governing Body, three (3) weeks prior to the start of the current season. Approval will be sent to the player within two weeks of the request for exception. There is no appeal from the decision of the LGB or the ALA. Exceptions are valid ONLY for the current season.

5.04.1 Overage requests may be approved by the LGB or the ALA, if there is no Local Governing Body, on a case by case basis for reasonable medical accommodation, player safety, if there is not an appropriate division team with roster spots available in the players Boundary as per ALA Regulation 1, or preservation of a program.

5.04.2 Underage players may be approved by the LGB or the ALA, if there is no Local Governing Body, on a case by case basis for reasonable medical accommodation, player safety, if there is not an appropriate division team with roster spots available in the players Boundary as per ALA Regulation 1, or preservation of a program.

- 5.04.3 A listing of all exceptions must be provided to the ALA Office complete with the reason for approval of the exception.
- 5.04.4 Overaged players are not permitted to participate in provincials/tournaments unless the player has approval by the ALA Executive by May 1 for Box Lacrosse and July 15 for Field Lacrosse. Leagues approving overaged players MUST have parents sign a waiver and witnessed by a league representative confirming they understand participation in tournaments and provincials is prohibited.

5.05 Playing in a Higher Age Division as Affiliates

- 5.05.1 Affiliations from Minor lacrosse to Major Lacrosse must be requested by the RMLL coach or manager to the potential affiliate players' head coach or manager. The potential affiliated players' head coach or manager must receive approval from the parent of the player. These approvals must be communicated by the potential affiliate players' head coach or manager to the RMLL team copying the minor club president and the minor LGB President or Executive Director.
- 5.05.2 Affiliations from 16U to Junior are unlimited.
- 5.05.3 Affiliations from Minor lacrosse to Senior B and Senior C lacrosse is prohibited.

REGULATION 6 - REGISTRATION DEADLINES

All ALA Players, Coaches, Trainers, Officials, and Executives must be registered in the ALA Registration system and agree to the ALA waiver prior to participating in any ALA sanctioned event.

- 6.01** The registration start date for registration of players and teams for the ALA Box Season, as per 8.01 is December 1 and the deadline is May 15 for minor box and July 15 for Major Box and Masters (**Note: Players signed and released prior to July 1 may be added to another team's roster until 11:59 pm July 15.**)
- 6.02** The registration start date for registration of players and teams for the Winter Box Season as per 8.02 is September 1 and the deadline is January 31.
- 6.03** The registration start date for players and teams for ALA Field Season as per 8.03 is April 1 and the deadline is August 1.
- 6.04** The registration start date for players and teams for Fall Field Season as per 8.04 is August 15 and deadline is January 31.
- 6.05** Late registrations may be accepted by the Director of Administration but there may be a \$50.00 penalty assessed to the registering Member for each registrant the Member registers late. Late player registrations are not permitted in Major Lacrosse.
- 6.06** Major Box Lacrosse Teams cannot register more than twenty-five (25) and not less than sixteen (16) players.
- 6.07** New Major Lacrosse Franchises and major lacrosse teams changing divisions must notify the ALA at the time of application to the RMLL.

- 6.08** Minor Box Teams cannot register more than twenty (18 players and 2 goalies) and not less than twelve (12) players.
- 6.09** Men's Field Lacrosse Teams cannot register more than twenty-three (23) and not less than fifteen (15) players for U12 and above. Men's Field Lacrosse Teams cannot register more than eighteen (18) and not less than twelve (12) players in U10. Men's Field Lacrosse teams cannot register more than eighteen (18) and not less than nine (9) players in U8 and U6.
- 6.10** Women's Field Lacrosse teams cannot register more than eighteen (18) and not less than fourteen (14) players for U15 and above. Women's Field Lacrosse teams cannot register more than eighteen (18) and not less than twelve (12) players for U12. Women's Field Lacrosse teams cannot register more than eighteen (18) and not less than nine (9) players for U8.
- 6.11** Exceptions are made in Junior B Tier III, Junior Ladies, and Senior B, where rosters may not exceed thirty (30), in Senior C and Senior Women's where rosters cannot exceed forty (40), and in Tier II where rosters may not exceed thirty (25 Tier II players and 5 Tier III players) and in 6U where teams may register a minimum of seven (7).
- 6.12** Any further exceptions to 6.06, 6.08, 6.09, 6.10, and 6.11 may be considered by the ALA Executive on a case by case basis for the current season only.
- 6.13** Minor Box registration shall not close before the 15th day of March of any given season.
- 6.14** Alumni players may register with the ALA office via an Excel spreadsheet for a single exhibition game with no applicable fee to the ALA.
- 6.15** All Players must be registered on teams.
- 6.16** All Teams must have registered bench personnel (volunteer or contracted) in the ALA Registration System. Bench personnel will consist of all coaches and a trainer. All Female only teams must have a female registered to the team and on the bench for games. Bench personnel must correspond to game sheets.
- 6.17** All Alberta Lacrosse Referee Association Officials must be registered in the ALA Registration system.
- 6.18** The mandatory fields for all registrations are: first name, last name, DOB, address, city, postal code, province, gender, home phone or cell number and primary e-mail address. This is for all executive, bench personnel, players, and Alberta Lacrosse Referee Officials.
- 6.19** The fine for each missing mandatory field will be \$25.00. The fine is invoiced per player per missing field to a maximum of \$500 per ALA Member at the ALA discretion.

REGULATION 7 - MEMBER RESPONSIBILITY - PLAYER ELIGIBILITY VIOLATIONS

- 7.01** Members shall be responsible to ensure that their players are eligible to play for their team in accordance with the ALA and CLA Operating Policy.

- 7.02** An ineligible player includes the following:
- a) A player not properly registered or improperly registered within the local governing body, ALA and CLA Operating Policy;
 - b) A suspended player; or
 - c) A player improperly released in accordance with the local governing body, ALA, and CLA Operating Policy.
- 7.03** If anyone participates in a game or if their name appears on the game sheet while ineligible, the persons responsible shall be subject to immediate discipline and the team shall forfeit any points earned from any games played using an ineligible person.
- 7.04** In any disciplinary proceeding arising out of a violation of this regulation, where it is established that the person or member who or which is the subject matter of the discipline proceedings should have known of the ineligibility of the player, and if in defense of the disciplinary action, it is submitted that the ineligibility was not known, the burden of proving the lack of knowledge is on the party who is the subject of the disciplinary proceeding.
- 7.05** Players eligible for Major Lacrosse (RMLL) graduating 16U draft are those players registered with an ALA Minor Lacrosse Member (as per the ALA registration system) in the year previous of the player becoming eligible to register for ALA Junior Registration as per 5.03.1.
- 7.05.1 Players eligible for the 2021 Major Lacrosse (RMLL) graduating minor lacrosse draft are those players registered with an ALA Minor Lacrosse Member (as per the ALA registration system) in 2019 Box Lacrosse Season or the 2020 Box Return to Activity/Sport Season and are born in 2004.
- 7.06** Only players who are registered in the ALA registration system, the season prior, to the submission of the CLA negotiated list can be protected by an ALA team on the CLA Negotiation List.
- 7.06.1 In 2021, players who were registered in the ALA registration system for the 2019 Box Season and/or the 2020 Box Return to Activity/Sport Season can be protected by an ALA team on the CLA Negotiation List.
- 7.06.2 Players who were on the CLA Negotiation List for Alberta in 2020 and did not complete a CLA Transfer in 2020 can be protected by an ALA team in 2021.
- 7.07** ALA Members participating in non-ALA sanctioned events are not covered by ALA insurance.

REGULATION 8 – ALBERTA LACROSSE PLAYING SEASONS FOR REGISTRATION PURPOSES

- 8.01** The ALA Box Lacrosse season for players registered as per 6.01 is March 1 to September 31.
- 8.02** The ALA Winter Box season for players registered as per 6.02 is October 1 to February 28.
- 8.03** The ALA Field season for players registered as per 6.03 is June 1 to October 31.

- 8.04** The ALA Fall Field season for players registered as per 6.04 is September 1 to March 1.
- 8.05** All Members notify the ALA office of Winter Camp/Drop In dates, location, divisions participating. All Winter Camps/Drop In must have CLA Minimum Standard coaches on the floor.

REGULATION 9 - EXHIBITION GAMES

All exhibition games between teams from different Local Governing Bodies or teams, without a local governing body must be sanctioned by the ALA.

- 9.01** All teams are to have written permission from the appropriate Local Governing Body or club President (for teams without a Local Governing Body).
- 9.02** During exhibition play, the number of players dressed for major lacrosse may be modified with the agreement of both teams. Teams can dress up to twenty-two (22) runners and three (3) goalies.
- 9.03** The host team must supply floor time and assure scheduling and payment of officials through the Alberta Lacrosse Referees Association.
- 9.04** Confirmation of all requirements must be supplied to both Local Governing Body Presidents or Club President (for teams without a Local Governing Body) and the ALA office at lisa@albertalacrosse.com
- 9.05** The ALA office will confirm sanctioning once all requirements are met.

REGULATION 10 – TRAVEL PERMITS

- 10.01** All teams which travel, out of the jurisdiction of the ALA, shall complete and file the necessary Travel Permit Request complete with roster of players, coaches and team management with a fee of \$150 cashable cheque and \$250 bond cheque to the ALA office. All players and personnel must be registered with the ALA. All coaches must meet the CLA Minimum Standards for applicable division. Upon return to Alberta, all copies of game sheets must be filed with the ALA office within 5 days. Once the game sheets are received by the ALA Office the \$250.00 bond cheque will be returned upon the filing of the game sheets with the ALA office. If the game sheets are not filed, then the bond check will be cashed. All competitions must be sanctioned by Member Associations of the Canadian Lacrosse Association or in the case of Internationals competitions by the analogous governing bodies. Upon approval of the request the team may travel to the competition.
- 10.02** The Travel Permit Request must be filed with the ALA Office a minimum of 15 days prior to the departure date complete with coaching staff, trainers and player roster.
- 10.03** A non-refundable late filing fee of \$75.00 will apply to all teams failing to file the travel permit on time.
- 10.04** Approval or disapproval will be given within 7 days after the travel permit has been received.

- 10.05** When a party applies for a travel permit the Executive Director checks all credentials and confirms that everything is in order. If everything is in order, the Executive Director, then gives conditional approval. The Director of High of Performance then sanctions the travel permit. If the Director has any issues, they must refer the issue to the Executive Committee for discussion and approval.
- 10.06** Any team playing ineligible players, unapproved bench personnel on game sheet traveling without proper authorization, or valid travel permit will be subject to a \$500 fine and the coach will receive an automatic one year suspension.
- 10.07** No team associated with a club that is part of the ALA may play or participate outside the jurisdiction of the ALA without first obtaining permission. Permission is obtained by acquiring a Travel Permit from the ALA. No ALA team is permitted to purchase independent insurance and travel outside the jurisdiction of the ALA.
- 10.08** Travel permits will not be issued for any ALA blackout dates.

REGULATION 11–TOURNAMENTS

- 11.01** No team registered with the ALA shall compete in any tournament in Alberta unless that tournament has been sanctioned by the ALA.
- 11.02** A tournament is defined as a contest involving a number of teams who play against each other in a series of games and will require ALA sanctioning prior to taking place in the province.
- 11.03** The Box and Field Lacrosse Tournament Permit Request must be submitted to the ALA Office prior to November 1st. complete with tournament rules for approval.
- 11.04** Prior to submitting tournament requests to the ALA, all requests must be approved by the Local Governing Body.
- 11.05** Minor Box Lacrosse Tournament Rules and Regulations will be as per the ALA Provincial Regulations. Failure to comply with Regulation 28 will result in a \$750 fine. Tournaments permitting overaged players will be fined \$750 per player.
- 11.06** Men’s Field Lacrosse Tournament Rules and Regulations will be as per the ALA Provincial Invitational Tournament Regulations. Failure to comply with Regulation 29 will result in a \$750 fine.
- 11.07** Women’s Field Lacrosse Tournament Rules and Regulations will be as per the ALA Provincial Invitational Tournament Regulations. Failure to comply with Regulation 30 will result in a \$750 fine.
- 11.08** Major Box Lacrosse tournaments are as per RMLL Regulations.
- 11.09** The tournament schedule must be provided to the ALA office at least two (2) weeks in advance of the first game of the tournament. Teams cannot be scheduled for more than 3 games in any given day and less than two (2) hours apart.

- 11.10** The host organization of any tournament shall, within 48 hours of the end of its tournament, file with the ALA office and its Local Governing Body a report outlining any discipline problems, accompanied by the corresponding game sheet (if applicable) which resulted in 5 minute penalties and any suspensions of any official, player, coach, manager or other person. Tournament discipline is to be supplied on discipline template provided to discipline chair. Failure to supply discipline reports will result in a \$500 fine to the host organization. If the suspended official, player, coach, manager or other person is not a member of or subject to the jurisdiction of such Local Governing Body (i.e. a visiting team from another LGB or MA) the Local Governing body shall within 48 hours of receipt of such report forward a copy of same to such suspended parties Local Governing Body or equivalent authority which has jurisdiction over such suspended official, player, coach, manager or other person.
- 11.11** All tournament chairs must supply the ALA office with the Tournament Standing Report within 48 hours after the final game of the tournament. Failure to supply report will result in a \$500 fine to the host organization.
- 11.12** All tournaments are to have a Discipline Chair and Referee In Chief.
- 11.13** A tournament permit fee of \$150.00 is to accompany the Tournament Permit Request.
- 11.14** A non-refundable late filing fee of \$100.00 will be charged should the deadline not be complied with and if the tournament is sanctioned by the ALA
- 11.13** Approved tournaments requesting changes to dates or add divisions will be subject to a \$100 change fee.

REGULATION 12 - TEAMS ATTENDING NATIONALS

- 12.01** Any teams wishing to attend a National Competition must have their CLA Team Registration Form signed off by the Executive Director one week prior to the applicable National Competition. No application will be approved where:
- (a) any player or other personnel on the roster is not in good standing.
 - (b) the team has not complied with CLA Policy on coaching certification applicable to the Competition.
 - (c) the team has not complied with the CLA Policy on CCES (Canadian Centre for Ethics in Sport) training.
 - (d) Fines resulting from late filing of the Team Registration form are the responsibility of the offending team.
- 12.02** Teams attending Minor Nationals Competition must be managed, organized, and approved by the ALA.
- 12.03** Teams attending Founders Cup, Presidents Cup and the Minto Cup must be the ALA Provincial Champion other than as per the hosting agreement.
- 12.04** In the event the Provincial Champion cannot attend the ALA Executive will select the ALA Representative to attend.

REGULATION 13 – BIDS FOR MAJOR BOX NATIONALS

13.01

In Major Box, the bids for hosting a CLA Major Lacrosse National Championship shall be submitted to the RMLL Executive Director and one shall be chosen by the RMLL BOD. The RMLL's choice of the successful bid shall be forwarded to the Director of High Performance via the ALA office together with all bid materials for ratification no later than January 15, of the year prior to the competition. The Director of High Performance will forward to ALA Board of Directors for ratification

REGULATION 14 - ALA SAFETY AND EQUIPMENT

14.01

Safety Policy

The fundamental concepts of the safety policy are to establish a standard of care intended to reduce the risk of injury from contact which is inherent in and incidental to the sport and to identify the responsibilities of the various participants.

14.02

General

Player safety and the use of proper equipment is the responsibility of many parties including:

- a) players and parents (of minor players: 17 years of age and under as of January 1 of the current year) are responsible for providing and maintaining proper equipment;
- b) coaches, trainers and team personnel are responsible for inspecting players equipment and preventing the use of improper equipment;
- c) game officials are responsible for enforcing the CLA rules of the game;
- d) all players are required to wear protective equipment as described and/or limited in the rules of play approved by the ALA and CLA;
- e) in Box Lacrosse the use and/or prohibition on the use of protective equipment shall be as published by the ALA and CLA in the Rules of Box Lacrosse and the CLA Equipment Review Committee;
- f) in Men's Field Lacrosse the use and/or prohibition on the use of protective equipment shall be as published World Lacrosse and the CLA Equipment Review Committee.
- g) in Women's Field Lacrosse the use and/or prohibition on the use and/or prohibition on the use of protective equipment shall be as published by World Lacrosse and the CLA Equipment Review Committee;
- h) equipment shall be manufactured by a CLA approved manufacturer, and shall not be altered in any way which will decrease the protection to the player, increase the risk of injury to an opponent or void the manufacturer's warranty;
- i) any equipment which violates this policy and/or the rules of play will be removed from the game and, where required, appropriate penalties will be given;

- j) where equipment dangerous to an opponent has been used, the game officials shall report the occurrence, via the standard incident report, to the appropriate governing body.

14.03 Equipment

- 14.03.1 For Box Lacrosse and Men's and Women's Field Lacrosse, all players shall wear Equipment as directed and approved by the World Lacrosse and the CLA Equipment Review Committee.
- 14.03.2 Only CLA approved balls may be used for practices and games. Yellow balls are required for Women's Field Lacrosse
- 14.03.3 Goggles are required for Women's Field Lacrosse.
- 14.03.4 MOUTHGUARDS. All players/goalies, of all age (with the exception of 6U players/goalies) are required to use a mouthguard as it was intended by the manufacturer unless a medical doctors or dentists' letter is supplied for the applicable season to the ALA and the LGB. This letter must be attached to the game sheet for each game played by the player. Any player/goalie who does not use a mouthguard as it was intended by the manufacturer, shall be assessed a 2 minute delay of game penalty and a 10 minute misconduct. In order for the penalized player to remain in the game, the penalized player must immediately use a mouthguard. In the event the goalie was assessed the penalty, a player on the floor must serve the penalty and misconduct. In order for the goalie to remain in the game, the goalie must immediately use a mouthguard as it was intended by the manufacturer. Failure to do so will result in the goalie being removed from the floor. A second penalty to the same player/goalie, in regards to mouthguards, will also result in a game misconduct and an official game report shall be forwarded to the local governing body.

14.04 Playing Surface

- 14.04.1 ALA Members who allow individuals on the playing surface during game period intermission without a helmet and face mask are subject to a first offence being a fine in the amount of \$250, and a second or subsequent offence being a fine in the amount of \$500. This regulation applies to all individuals under 18 years of age. The fine will be payable by the home club.
- 14.04.2 Players, coaches, referees, and volunteers (under 18 years of age on December 31 in the year in which they wish to participate) must wear a helmet on the playing surface excluding coaches on the bench during a game.

REGULATION 15- RULES OF PLAY BOX LACROSSE

- 15.01** Rules of play in Alberta shall be those of the CLA Rule Book for the current season. In order to ensure uniformity, there will be no variation of the CLA Rules and officials shall enforce CLA Rules with the following enhancements:
- 15.02** Abuse by Fans (See Regulation 23)
- 15.03** Mouthguards (See Regulation 14)
- 15.04** Standardized Game Time for Box Lacrosse is as follows:

Division	Allotted Time	Warm-Up/Training	Period/Game 1	Period/Game 2	Period 3/Game	Period Break
6U	1 hour	5	15	15	15	3
8U	1 hour	5	15	15	15	3
10U	1 hour	5	15	15	15	2
12U	1 ¼ hours	5	15	15	20	2
12U COVID	1 hour	5	15	15	15	2
14U	1 ½ hours	5	20	20	20	2
14U COVID	1 hour	5	15	15	15	2
16U	1 ½ hours	5	20	20	20	2
16U COVID	1 hour	5	15	15	15	2
Junior B	2 ½ hours	30	20	20	20	10
Junior A	3 hours	60	20	20	20	10
Senior	2 ½ hours	30	20	20	20	10
Masters	1 ¼ hours	5	15	15	15	2

- 15.05** Except as specifically amended herein, all Periods shall be stop time as per CLA guidelines. In Minor Box Lacrosse, except 6U, 8U, 10U, and in Masters Lacrosse, the clock shall stop for goals, penalties, time-outs, and Officials discretionary stoppages (i.e. injury) with a minimum two (2) minute break between periods. In 6U, 8U, and 10U each game or period, as applicable shall be run time except that the clock will be stopped for timeouts. In Major Lacrosse, the clock shall stop for ALL stoppages including Penalties, Time-outs, and Referee Discretionary Stoppages (i.e. injury), and Possession Changes with a minimum ten (10) minute break between periods.
- 15.06** In 10U, 12U, 14U, and 16U Lacrosse, if five (5) minutes before the scheduled end time of the game time slot for league games, there is more than five (5) minutes left on the clock, the clock shall be reset to two (2) minutes and play shall continue in stop time to the end of the game, for each of 12U, 14U and 16U box lacrosse and straight time for 10U. As required, a game may be called at this time if an injury is present and cannot be taken care of in a timely fashion.
- 15.07** In 12U, 14U, and 16U Lacrosse if a goal differential of six (6) or more goals is present at any time during the game, at the next whistle to start play, the clock will run at straight time. If the goal differential is brought within four (4) goals, the clock shall return to stop time at that time. In Major Lacrosse (Junior / Senior), running time may be applied and will continue only at the discretion and agreement of both coaches. In cases where goal differential exists and both coaches cannot agree on running time, both Referees' may, in the interest of game management and/or player safety, make a discretionary decision to apply running time.
- 15.08** Except in 6U and 8U, during running time portions of the game, all time penalties shall run at their normal designated time (Minor – 2 minutes, Major – 5 minutes, Misconduct – 10 minutes, etc.)
- 15.09** In the event a team is late for reasons outlined in CLA Rule 19, the officials may allow 5 minutes past the normal start time of the game for the team to arrive unannounced. If the team that has been delayed has made contact with the arena directly or via persons

within the arena, the official shall provide an additional reasonable delay (up to 30 minutes)

15.10 If less than two (2) full periods of any game have been completed, then, at the discretion of the Local Governing Body (Director of Development if no LGB is available), the game shall be considered incomplete and the remainder of the game may be rescheduled for a suitable time.

15.11 The standardized game length will be extended for the purpose of overtime subject to Regulation 15.12.

15.12 The RULES OF PLAY outlined in this Regulation 15 shall apply to all games sanctioned by the Alberta Lacrosse Association (e.g. exhibition, regular season, playoff, and provincial played games). The ALA retains the right to enhance rules of play for the safety and betterment of the Sport of Lacrosse in the Province of Alberta.

15.13 During exhibition play, 15.04 may be modified with the agreement of both teams. When modifying 15.04, the Allotted Game Time, Warm-Up Time, Period Length and Period Break are to be pre-determined. In the event that 15.04 is modified, the referees officiating the game(s) are to be compensated according to the period lengths and allotted time for the next appropriate division (e.g. For 8U, 10U or 12U game where 3 x 20 minute periods are used, the officials will be compensated at a 14U rate).

15.14 There will be NO SHOT CLOCK at 8U and 6U.

15.15 6U rules

15.15.1 In 6U, Option L will apply. (Individual organizations will decide whether or not to use a goalie (based on number of players, availability of equipment, etc)

15.15.2 In LTAD option L, the following shall apply in addition to CLA Rule book:

- a) Fall Back Rule applies as per CLA Rule Book
- b) Games will be cross floor to a maximum of two (2) games per floor.
- c) Each team shall be composed of three players, one designated goalkeeper and a recommended 6 substitute players for a total recommended team size of ten players.

15.16 8U rules

15.16.1 In 8U, Option L will apply.

15.16.2 In CLA LTAD option L, the following shall apply in addition to the CLA Rule book:

- a) Fall Back Rule applies as per CLA Rule Book

15.17 10U Rules

15.17.1 All 10U box lacrosse games shall be played in accordance with CLA Rules according to LTAD Option L.

15.18 Major Lacrosse

- 15.18.1 Major Box Lacrosse will be conducted pursuant to ALA and RMLL Rules, Regulations, and Policies.
- 15.18.2 In Major Lacrosse, the shot clock will be run in all situations.

15.19 Masters Lacrosse

Rules of play in Alberta shall be those of the CLA Rule Book for the current season. In order to ensure uniformity, there will be no variation of the CLA Rules and officials shall enforce CLA Rules with the following enhancements:

15.19.1 Ball Movement

- a) There will be NO "2 player" rule.

15.19.2 Shooting

- a) No deliberately reckless shot should be taken through a crowd.
- b) Any offensive player who hits any other player (offensive OR defensive) other than the goalie, or the official with a shot shall be assessed a minor penalty for dangerous shot. This rule applies regardless of where the shooter is when the shot is taken. The dotted line has absolutely no bearing in the interpretation of this rule.
- c) Any shot taken from behind the net that hits the goalie will be considered a dangerous shot. No goal will be awarded in this situation. If the offence is considered minor in nature, the result will be loss of possession. If the offence is more serious in nature as determined by the official, a minor penalty can be given to the shooter.
- d) Any player who receives two (2) dangerous shot penalties in the same game will be expelled for the balance of the game.

NOTE: For clarification; any shot that goes straight in without hitting anyone with the exception of the goalie, CANNOT be considered dangerous. Any shot that hits ANYONE with the exception of the goalie is reckless, and therefore a dangerous shot. In addition, any shot that is considered by the official to be intentionally reckless, that does not result in a goal and does not hit anyone, should receive a warning from the official. Any player who continues to shoot recklessly through a crowd can be given a dangerous shot penalty at the discretion of the official.

15.19.3 Contact

- a) A defensive player may check an offensive player by placing the head of their stick on the stick of the player they are defending. However, any stick check that is considered to be dangerous, reckless, careless, or overly aggressive by the official will be called slashing.
- b) No deliberate body contact is permitted, offensive (charging) or defensive (interference).
- c) Offensive picks are considered illegal, offensive screens that do not initiate contact as long as the player setting the screen is stationary and does not extend their stick are considered legal.

- d) A defensive player cannot make contact with an offensive player unless their hands are closed and placed together on their stick. Place and push only.

15.19.4

Penalty Shots

- a) All penalty shots will start with the shooter standing at centre, and all other players, both offensive and defensive, behind the trailing restraining line. Once the shooter crosses the attacking restraining line, the other players will be allowed to give chase. At this point the ball is live, and the play will continue as if the shooter was on a breakaway.

REGULATION 16—4 ON 4 BOX LACROSSE

16.01

Game Play

- 16.01.1 Each team shall be composed of up to thirteen (13) players, including a maximum of two (goaltenders). For an infraction of this rule, a bench minor penalty shall be assessed to the offending team and the extra player(s) removed from the game. Bench minor penalties require the removal of any player on the offending team (other than the designated goalkeepers) without a substitute for two minutes unless terminated by a goal.
- 16.01.2 Each Team shall be allowed one goalkeeper on the floor at one time. The goalkeeper may be removed, and another player substituted. Such substitute shall not be permitted the privileges of the goalkeeper.
- 16.01.3 The game shall be played with four (4) players and one (1) goaltender on the floor for each team. For an infraction of this rule, a bench minor penalty shall be assessed to the offending team and the extra player(s) removed from the game. Bench minor penalties require the removal of any player on the offending team (other than the designated goalkeepers) without a substitute for two minutes unless terminated by a goal
- 16.01.4 Teams will be given a 3-minute warm up prior to each game.
- 16.01.5 The duration of the game shall be three 15-minute run time periods, with a 3-minute intermission between periods. Each period shall start with a face-off. The clock shall only stop for an injury.
- 16.01.6 If a ball makes contact with the mesh surrounding the arena, the ball shall be deemed out of bounds' and possession shall be awarded to the non-offending team.
- 16.01.7 12-Second Count: In all 14U and older divisions, in all situations, there shall be a twelve – (12) second count half-court applicable to both teams. When a team gains possession in the defensive half of the floor, they must get the ball across the centerline within twelve (12) seconds of gaining possession.
- 16.01.8 14-Second Count: In all 12U divisions, in all situations, there shall be a fourteen – (14) second count half-court applicable to both teams. When a team gains possession in the defensive half of the floor, they must get the ball across the centerline within fourteen (14) seconds of gaining possession.
- 16.01.9 12/14-Second Count Procedure: The 12/14-second count shall be kept by the trailing referee on the floor by a chopping wave of the hand for each second.
- 16.01.10 Timeouts Called in the Defensive Half of the Floor: In time-out situations called by either team before the expiration of the 12/14-second count, a new 12/14-second count shall be awarded after the time-out.

- 16.01.11 Back-Court Definition: Teams must keep the ball in their offensive half after gaining possession or carrying the ball with both feet across and making contact in that zone. Possession will be awarded to the non-offending team.
- 16.01.12 Back-Court Violations:
- a) If a loose ball or a player with possession of the ball comes in contact with the centerline of the field for any reason other than a shot on goal or the defensive team being the last to touch the ball, it shall be a back-court violation.
 - b) If the offense was the last to touch the ball without a reset of the shot clock, as it goes into the back-court, the referee shall not blow the whistle until it is apparent where the ball comes to rest, so it can be allocated to the non-offending team in that location, with the exception of in front of the goal. Immediately in front of the goal is deemed approximately a 10-yard radius from the center point of the top of the goalie crease.
 - c) The offensive team cannot intentionally direct the ball into the back-court for any reason regardless if they are considered to have possession or not. Should a goalie be pulled for an extra attacker when the ball travels across the center and travels into the goal, this play is regarded as a good goal.
- 16.01.13 Crease Play: See changes to the CLA Rule crease play rule in Regulation 16.05
- 16.01.14 Off-Ball Contact: See changes to the CLA cross-checking rule in Regulation 16.05
- 16.01.15 There is to be no overtime during regular games. Two (2) points awarded for a win. One (1) point for a tie. Zero points for a loss.
- 16.01.16 In semi-final and final games: If a tie occurs, a shootout will decide the winner:
- a) Each team shall select 3 shooters
 - b) Each team shall alternate equal chances to score
 - c) If tied after all 6 initial shooters attempt to score, teams will alternate single attempts to determine the winner in sudden victory on equal chances.
 - d) Shooters may not be repeated until all players have attempted to score in the shoot-out.

16.02 Penalties

- 16.02.1 All penalties in the CLA Rulebook shall apply, with the exception of those listed in 16.05.
- 16.02.2 10-minute misconducts shall result in an expulsion for the remainder of the game, not to carry to the next game.
- 16.02.3 Game Reports shall be electronically filed for all penalties listed under CLA Rule 23(L), as well as any incidents of fighting.
- 16.02.4 Any player receiving three (3) penalties in one game shall receive an expulsion for the remainder of the game, not to carry to the next game. A double minor shall count as two (2) penalties toward the maximum of three (3).

16.03 Tie Break Formula

- 16.03.01 If teams are tied in their record during seeding for semi-finals, the teams shall follow the tie break procedure as follows:
- a) Head-to-head result

- b) Formula: (Goals For) / (Goals for + Goals against) GOALS FOR GOALS FOR + GOALS AGAINST
- c) The formula is applied once to rank all tied teams d) Least Goals Against

16.04 4 on 4 Tournaments

16.04.01 All 4 on 4 Tournaments must follow Regulation 11 – Tournaments unless given written permission by the Director of High Performance for an exemption.

16.05 Amendments to Existing CLA Rules

1. Rule 40 – Cross-Checking

A defender who cross-checks a player, who is in a stationary position and not in possession of the ball shall be assessed a penalty. A player who uses excessive unequal pressure and force to cross-check a non-stationary opponent, not in possession of the ball, shall be assessed a penalty

2. Rule 39—Crease Infractions

39.1 Attacking Player First Touch/Interfere After Shot On Goal

- If an attacking player who, after taking a shot on goal, or making a pass, steps by way of his momentum into the crease and then immediately out, is not in violation of the goal - crease area provided the attacking player is not the first to touch the ball (not including after a touch by the goalie) and or directly interferes with an opposing player who is attempting to pick up the ball.

39.2 Attacking Player In Crease

- An attacking player in possession of the ball is in violation of the crease if any part of his body is on the line or inside the crease. A player who is in contact on the crease line or in the crease with his stick only is not in violation of this rule.

39.3 Attacking Player First Touch/Interfere After Shot On The Goal

- If an attacking player who, after taking a shot on goal, or making a pass, steps by way of his momentum into the crease and then immediately out, is not in violation of the goal - crease area provided the attacking player is not the first to touch the ball (not including after a touch by the goalie) and or directly interferes with an opposing player who is attempting to pick up the ball.

39.4 Attacking Player in Crease to Gain Advantage

- An attacking player who is in contact in the opposing crease and exits, thereby gaining an advantage as deemed by the discretion of the official and makes contact with the ball or directly interferes with an opposing player who is attempting to pick up the ball is in violation and possession shall be awarded to the nonoffending team. An attacking player who is not in possession of the ball and is in contact in the opposing crease and then exits the crease and is the first to receive a pass immediately after exiting the crease is in violation and possession shall be awarded to the non-offending team.

39.5 Attacking Player in Crease to Gain Advantage on Defender

- An attacking player who is in contact in the opposing crease and exits, thereby gaining an advantage, as deemed by the discretion of the official and initiates contact on an opponent who has possession of the ball is in violation and will be assessed a delay of a game minor penalty.

39.6 Non-Shooter In Crease When Teammate Shoots

- A non-shooter who is in the opposing crease must vacate the crease by establishing body contact outside the crease prior to the ball crossing the plane of the goal to be an awarded goal.

39.7 Shooter in the Crease Prior to the Ball Crossing the Goal Line

- Any attacking player, while shooting, who makes contact with the crease prior to the ball completely crossing the goal line will result in no goal and a possession infraction. Should an attacker shoot the ball resulting in the ball contacting the goalie and then contacting a defender and the ball travels across the plane of the goal, a goal shall be awarded provided the shooter is out of the crease prior to the ball completely crossing the goal line.

39.8 Contact with Goaltender

- A crease violation occurs when contact is made between the attacking player and/or stick and goaltender, while the attacking player is in the crease. NOTE: A goaltender who reaches out with his stick and makes contact with an attacker who is in the crease is not a crease violation. NOTE: An attacking player, while in the crease who makes contact with a defender, and whereby the defender then makes contact with the goaltender, the attacking player shall be called for a crease violation. Incidental contact, at the discretion of the referee, by an attacker who is in the act of shooting on a goaltender and makes contact with his body or stick which in no way affects the ability of the goaltender to attempt to make a save or play the ball shall not result in a crease violation provided the ball enters the goal. If the ball does not enter the goal from the attacker shooting and contact is made within the crease between the goalie and the shooter, play will be blown down immediately and possession awarded to the non-offending team.

39.9 Attacker and Ball in the Crease

- A crease violation occurs when an attacker is in the crease, at the same time as the ball, and inhibits and/or interferes with the goalies' attempt to retrieve the ball, resume play and/or perform normal duties of play. Play shall be stopped immediately, and possession awarded to the non-offending team. Should the attacker be in the crease, at the same time as the ball, and in no way affects the goalie to perform normal duties of play, play shall continue with no crease violation, however, should a goal be scored in this scenario it would be disallowed

39.10 Contact by a Defender

- When an offensive player has been legally checked by a defender into the crease prior to the ball completely crossing the goal line, no goal will result. When the attacker has been illegally checked by a defender into the crease, the official will signal a delayed penalty and should a goal be scored the goal will count provided the offensive player or team is not in violation of any other rules.

39.11 Goalie Hand Ball

- A goalkeeper may catch the ball while in his crease (deemed two feet in his crease) with the gloved hand but cannot catch with his hand and/or stick and then throw with the hand; he can only put it in the stick and throw. If the goalie throws the ball with his hand, possession shall be awarded to the non-offending team. A goalie is permitted to use his hand to drop the ball into a teammate's stick within his crease only. A goalie cannot use his hand to grasp, touch or hold the ball outside his crease. A violation results in possession to the non-offending team.

39.12 No Re-Entry by Player

- The defending player, including the goalkeeper with the ball in his possession, may not enter the goal - crease area. Nor may he remain in the goal - crease area in possession longer than four seconds.

39.13 No Re-Entry by Ball

- A goalie or a defending player in the crease is not allowed to make contact with a ball that has been deliberately directed or passed back to the crease by a teammate. If a deliberately directed ball is deflected by an offensive player this will not be considered re-entry. A defender while in the crease is allowed to pick up a non-deliberately directed loose ball outside the crease. A defender who is outside the crease and gains possession of the ball that is in the crease, that has not been deliberately directed or passed back to the crease by a teammate, may legally step into the crease.

39.14 Checking A Non-Goalie Who Has Possession In The Crease

- When a defending player other than the goalie is in his own crease with possession, opposing players may not enter the crease to bodycheck said, player. Opposing players may check the stick of the ball carrier when said player has two feet in the crease and the ball and stick is outside the crease. This rule applies if the goaltender is in or out of the crease. The opposing players may attempt to intercept a pass by the said player and stick-on-stick contact is allowed outside the crease. Violation of this rule shall result in a two (2) minute penalty for goalie interference or more serious penalties if warranted.

39.15 Ball Ensnared In Netting

- Should the ball be continuously contacting or resting on the back of the netting, the referee shall stop play and the ball is given to the goalie in his crease.

39.16 Penalty Shot

- Should a player in his own end deliberately fall on the ball in his crease in front of his goal line, or deliberately closes his hand on the ball in his crease in front of his goal line, a penalty shot will be awarded.

REGULATION 17 – 16U A LEAGUE

The Alberta Lacrosse Association (ALA) 16U Box Committee will be comprised of one representative from each LGB with a team competing in the league, the Director of Development of the Alberta Lacrosse Association, and an ALA Staff Member. The Chair of the ALA 16U Box committee will be the Director of Development. This committee will set for the direction of the league and make decisions related to the operations of the league. Each LGB will have one vote on league decisions with the Director of Development having a vote. The ALA Staff Member will have no vote on the committee.

17.01 League Composition

The league will be comprised of 16U teams registered in an LGB

17.02 Team Boundaries

Team boundaries will follow the current boundaries established within each LGB. Any boundary questions or adjustments should be made through the appropriate LGB. The boundary adjustments must be communicated to the 16U Box Committee Chair and the ALA Staff Member.

17.03 Declaration for Entry into the League

Teams applying to participate in the Alberta 16U Box League must declare to the Committee by February 15 of the prior year for entry into the following season. The application must provide the following information:

- CLUB AND LGB SUPPORT
- PROPOSED BOUNDARIES

17.04 League Playing Rules

17.04.1 The league will follow all the rules and regulations of the Alberta Lacrosse Association as per ALA Regulation 15. There will be no overtime games in regular season play.

17.04.2 Any ties in end of the season standings will follow the Alberta Lacrosse tie breaking formula as per ALA Regulation 28.

17.04.3 The League will follow Regulation 21 for Automatic and Other Suspensions.

17.04.4 Regulation 20 – Enforcement of Offence/Defence Tactic in Minor Lacrosse will be strictly enforced.

17.05 Affiliation Process

17.05.01 Affiliations are drawn from a pool of 10 Affiliated Players declared for each team by May 1 of each season. Affiliate players may consist of club or Zone team players from a level below or division below

17.05.02 Suspended players cannot be affiliated. If suspended, as an affiliate player, the suspension must be served with the players original ALA Registered Team.

17.05.03 Player affiliations may not be withheld from registered team unless there is a conflict with the rostered teams regular scheduled game or practice.

17.05.04 Illegal affiliations will result in a \$50.00 fine for the first occurrence. The second occurrence will result in a \$50.00 fine and a one game suspension. The third occurrence will result in a discipline referral to the 16U Box Committee.

17.05.05 Affiliations for Provincial Play shall follow the Affiliation rules as per Regulation 28.

17.06 League Discipline Committee

Discipline within the league will be handled by a League Discipline Committee comprised of the ALA Staff Member, Director of Development and one member of the ALA Executive.

17.07 League Schedule

17.07.1 The league schedule will be based on home and away games against each team in the league.

17.07.2 League playoffs/provincials will be as per League Operating Policy.

17.08 Exhibition Games and Tournaments

17.08.1 Any team wishing to play an exhibition game must comply with ALA Regulation 9. All league commitments must be met prior to permission being granted. All exhibition game costs will be paid by the teams as per ALA Regulation 9.

17.08.2 Any team wishing to attend an out of province tournament comply to ALA Regulation 10 – Travel Permits. No tournament game shall be substituted for any scheduled league game.

17.09 Rescheduling of League Games

No league or playoff game will be altered or rescheduled unless special permission is granted in writing by the ALA Staff Member. Permission will not be granted unless the date(s) and time(s) of the rescheduled game(s) have first been obtained, which date(s) and time(s) are mutually agreed on by both teams. Rescheduling of game(s) must be submitted for approval 14 days before the scheduled game(s) with the new time(s) and date(s). All change fees as per ALA Regulation 32 will be responsibility of the requesting team.

17.10 Game Reports

17.10.1 The home team is responsible for supplying the game sheet, to their LGB and the ALA Office.. All affiliate players (AP) shall be designated as such on the game sheet beside the player's name.

17.10.2 In order to ensure no sanctions will be applied to your team the game sheet must be submitted by midnight of the game day. The ALA Staff Member shall have the authority to issue a fine in the amount of \$50.00 to any team that did not submit the game sheet in time or improperly filled out the game sheet.

17.11 Provincial Competition

All teams in 16U League will attend Provincials. Top 51% of teams in the league will be assigned in the A1 pool to play for A1 Provincial Championships. Bottom 49% of teams in the league will be assigned in the A2 pool to play for A2 Provincial Championships.

17.11.1 Teams in the A1 pool will pick their slots in the ALA provincial 16U schedule based on the final league standings.

REGULATION 18- RULES OF MEN'S FIELD LACROSSE

18.01 Rules of play in Alberta shall be those of the CLA Men's Field Rule Book for the current season. In order to ensure uniformity, there will be no variation of the CLA Rules and officials shall enforce CLA Rules with the following enhancements:

18.02 Men's Field Playing Rules

- a) The Canadian Lacrosse Association Rules of Field Lacrosse apply.
- b) The Canadian Lacrosse Association's Coaches Code and the CLA Coaching Philosophy for Field Lacrosse must be adhered to. Adherence to these Guidelines will be monitored and interpreted by the ALA Representative.
- c) All games will start on time unless otherwise decided upon by the ALA Representative.
- d) WARM UP: there will be a five (5) minute warm-up before game time.
- e) Game Times: full games will be run consisting of 4-15 minute quarters with the exception of the U10 division which will be 2-25 minute halves; U8 and U6 which will be 2 – 15 minute halves.
- f) Overtime: after a 5 minute rest, team will switch ends and the game will continue until the first sudden victory goal. Overtime periods will be 4 minute stop time periods with 2 minute rest in between
- g) A game is considered complete if 80% of the game time has elapsed.
- h) An interrupted game will restart at the point of the interruption.

18.03 U8 and U6 rules

18.03.1 Play will consist of 5 on 5 play (4 players and a goalie) with NO Long Poles

18.03.2 Play will be cross field from the restraining line to the end line using 6 x 6 nets and soft balls. The front of the crease is 8 yards from the end line.

18.03.3 Play will be non-contact with no off sides and no faceoffs after goals.

18.03.4 Players will be subbed out for fouls as there are no time served fouls.

18.04 U10 Rules

18.04.1 Play will consist of 7 on 7 play (2 attack, 2 midfield, 2 long poles, 1 goalie). Only two (2) long poles permitted on the field at one time.

18.04.2 Play will be cross field from the restraining line to the end line and will use 4 x 4 nets. The front of the crease is 8 yards from the end line.

18.04.3 Play will be non-contact.

REGULATION 19- RULES OF WOMEN'S FIELD LACROSSE

19.01 Rules of play in Alberta shall be those of the World Lacrosse Women's Field Rule Book for the current season. In order to ensure uniformity, there will be no variation of the Rules and officials shall enforce Rules with the following enhancements:

19.02 Women's Field Playing Rules

- a) The World Lacrosse Rules of Field Lacrosse apply. NCAA Crosses will be permitted.
- b) The Canadian Lacrosse Association's Coaches Code and the CLA Coaching Philosophy for Field Lacrosse must be adhered to. Adherence to these Guidelines will be monitored and interpreted by the ALA Representative.
- c) All games will start on time unless otherwise decided upon by the ALA Representative.
- d) WARM UP: there will be a five (5) minute warm-up before game time.
- e) Game Times: Full games will be run consisting of 2 – 25 minute halves with a 5 minute half time rest for U15. Full games will be run consisting of 2 – 20 minute halves with a 5 minute half time rest for U12. Full games will be run consisting of 2 – 15 minute halves with a 5 minute half time rest for U8. Teams will have one (1) two-minute timeouts per game. The clock shall only stop in the event of injury. Injured players must leave the field until the next scheduled substitution and shall be replaced by another player.
- f) Overtime: after a 5 minute rest, team will switch ends and the game will continue until the first sudden victory goal. Overtime periods will be 6 minute stop time periods with 3 minute rest in between.
- g) A game is considered complete if 80% of the game time has elapsed.
- h) An interrupted game will restart at the point of the interruption.

19.03 U8 Rules

19.03.1 Play will consist of 5 on 5 play (4 players and a goalie).

19.03.2 Play will be cross field from the restraining line to the end line use 4 x 4 nets and soft balls. The front of the crease is 8 yards from the end line.

19.03.3 Play will NOT include off sides and will NOT include draws after goals.

19.04 U12 Rules

19.04.1 Play will consist of 8 on 8 play (7 players and a goalie).

- 19.04.2 Play will be cross field from the restraining line to the end line use 6 x 6 nets. The front of the crease is 8 yards from the end line.
- 19.04.3 Play will NOT include off sides.

REGULATION 20 – ENFORCEMENT OF OFFENCE/DEFENCE TACTIC IN MINOR LACROSSE

- 20.01** The purpose of the enforcement is to ensure that minor box lacrosse players are given full opportunity to develop their offensive and defensive skills. The development and enjoyment of the players is the key principle that needs to be protected. The enforcement of the policy is in place as a deterrent and is to be used when there are valid concerns. Abuse of the enforcement policy will not be tolerated by the ALA.
- 20.02** The definition of a team using an offense/defence system will be when a team continuously incorporates a system in which a player, or players, are played on one end of the floor only. All players shall remain on the floor for both an offensive and defensive possession in each playing shift. A team will be deemed to have violated the policy if one or more players are found to be only playing in a defensive or offensive possession for more than one playing shift, or if a player, or players show a consistency of playing predominantly in only a defensive or offensive position during the game. The above only applies to all even-strength situations.
- 20.03** At all Minor box lacrosse, the LGB President/ ALA Coach Developer/Lacrosse Ambassador will be responsible for determining if a team is using an offense/defence system during the game.
- 20.04** If the LGB President/ ALA Coach Developer/Lacrosse Ambassador determines that an offense/defence system is being used by a coach in a game, the ALA representative will advise the offending team coaches at the end of the current period of play.
- 20.05** The first infraction will result in the removal of the Head Coach for the remainder of the game, or the Coach in charge of the bench if the Head Coach has previously been removed or suspended. If the violation occurs in the final period of the game, the Head Coach or the Coach in charge of the bench will be suspended for the following game.
- 20.06** The second infraction during the season will result in the expulsion of the Head Coach, or the Coach in charge of the bench if the Head Coach has previously been removed or suspended, for the remainder of the season. The suspended Coach or Coaches and the club involved will be referred to the ALA Discipline Committee for further review.
- 20.07** If a team does not have certified coaches from the ALA Registration System sufficient to complete the season, the team will forfeit all further games.

REGULATION 21 - AUTOMATIC AND OTHER SUSPENSIONS (MINOR BOX)

- 21.01** The ALA establishes the following suspensions including automatic suspensions under **Bylaw 10.01.4** from which there is no appeal. In this regulation, “committee”, in the case of a game being played outside of the boundary of the Local Governing Body of the involved offender or a game being played in an ALA or other CLA Member Association Sanctioned Tournament shall mean the Governing Body and/or Tournament Discipline/Appeal Committee. In the case of the ALA Provincials “committee” shall mean the ALA Provincial

Discipline/Appeals Committee. Otherwise, inside the boundary of the offender “committee” shall mean the Discipline/Appeals Committee of the Local Governing Body.

21.02 Automatic Suspensions

- 21.02.1 ABUSING OFFICIALS will result in an automatic MATCH PENALTY as per CLA Rule 62, with the individuals being suspended from further ALA sanctioned activities with such incident being referred to committee and the individual remaining suspended until the committee directs otherwise.
- 21.02.2 MATCH PENALTY as per CLA Rule 80 will result in individual being suspended from all ALA sanctioned activities. An incident report will be immediately filled out and sent to the committee
- 21.02.3 GROSS MISCONDUCT as per CLA Rule 48 will result in an automatic MATCH PENALTY with the individual being suspended from all further ALA sanctioned activities and the incident referred to committee
- 21.02.4 RECKLESS AND ENDANGERING PLAY: as per CLA Rule 30 will result in a MATCH PENALTY, with the individual being suspended from all further ALA sanctioned activities and the incident is referred to committee
- 21.02.5 MISCONDUCT OFF PLAYING FLOOR: refer to CLA Rule 79, with the individual being suspended from all further ALA sanctioned activities and the incident is referred to committee with the individual remaining suspended until the committee directs otherwise.
- 2102.6 GAME MISCONDUCT: as per CLA Rule 79, will result in individual being suspended for the remainder of the game, immediately leave the venue or go to the dressing room.
- 21.02.7 2nd GAME MISCONDUCT IN THE SAME GAME: The incident will be referred to committee with the player remaining suspended until the committee directs otherwise
- 21.02.8 CHECKING FROM BEHIND: Checking From Behind. as per CLA Rule 38 a player will receive a double minor penalty - or - a major penalty and a game misconduct – or – a MATCH PENALTY.
- 21.02.9 ABUSE BY FANS: as perceived by a referee, Tournament Chair, or other ALA Executive Committee Members, will result in having the referee have the coach ask his/her “fan” to immediately remove him/herself from the arena and not to return for the remainder of the game. The game will not resume until said fan is completely removed from the arena. If the fan refuses to leave within a reasonable time, the team to which the fan is related will forfeit the game. An incident report will be sent to the committee.
- 21.02.10 FIGHTING: a major penalty and a game misconduct will be assessed to any player/goalkeeper who fights.
- 21.02.11 FIGHTING IN THE LAST 10 MINUTES: a major penalty, a game misconduct and an additional one (1) game suspension in minor lacrosse.
- 21.02.12 FIGHTING OFF THE FLOOR: as per CLA Rule 45 (d), player is suspended from any further lacrosse activities. An incident report will be forwarded to the committee and the player remains suspended until the committee directs otherwise
- 21.02.13 INSTIGATING A FIGHT OR BEING AN AGGRESSOR: as per CLA Rule 45 (a) the player will receive a Major for Fighting and a Game Misconduct. As per CLA Rule 45 (b) an instigator or aggressor in a fight, a major penalty plus any other penalties shall be assessed

to the offending player(s). As per Regulation 21.02.7 player will be suspended for the remainder of the game, immediately leave the venue or go to the dressing room and the incident will be referred to committee with the player remaining suspended until the committee directs.

- 21.02.14 RESTARTING A FIGHT: In addition to CLA Rule 45 (c) this action will result in player being assessed a MATCH PENALTY.
- 21.02.15 SPEARING: in addition to the CLA Rule 65, the player will automatically receive a major penalty, a MATCH PENALTY and an automatic two game suspension and a referral to Committee, which may add a further suspension.
- 21.02.16 ATTEMPT TO SPEAR: in addition to CLA Rule 65, a five minute major penalty, a game misconduct, plus a one game suspension
- 21.02.17 BUTT ENDING: in addition to the CLA Rule 35, the player will automatically receive a major penalty, asses a MATCH PENALTY and an automatic two game suspension and a referral to Committee which may add a further suspension. The player may return to play if not notified by the Committee.
- 21.02.18 ATTEMPT TO BUTT END: in addition to the CLA Rule 35, a five-minute major penalty, a game misconduct plus a one game suspension
- 21.02.19 KICKING: In addition to CLA Rule 57, the player will automatically receive a major penalty, asses a MATCH PENALTY and an automatic two game suspension and a referral to Committee which may add a further suspension. The player may return to play if not notified by the Committee.
- 21.02.20 ATTEMPT TO KICK: In addition to CLA Rule 57, a five minute major penalty, game misconduct, plus a one game suspension.
- 21.02.21 REFUSING TO START PLAY:
- (a) with both teams on the floor, after the game has started, a team for any reason refuses to play after being ordered to do so in accordance with Rule 63 of the Canadian Lacrosse Association Rule and Situation Handbook, the designated Head Coach for that team shall receive a minimum six (6) game suspension from which there is no appeal.
 - (b) If prior to the start of a game or period, a team fails to begin play in accordance with Rule 63 of the Canadian Lacrosse Association Rule and Situation Handbook, the designated Head Coach for that team shall receive a minimum six (6) game suspension from which there is no appeal.
 - (c) The six (6) game suspensions referred to in subsections (a) and (b) shall begin immediately following the game in which the team refused to start play.
 - (d) The circumstances involving the suspension of the aforementioned Head Coach shall automatically be referred to the Alberta Lacrosse Association Discipline and Appeals Committee in the form of a complaint pursuant to section 10.01.5 of the Alberta Lacrosse Association Bylaws. Once referred, and should it deem necessary, the Alberta Lacrosse Association Discipline and Appeals Committee may conduct a hearing in accordance with the Bylaws and Regulations of the Alberta Lacrosse Association so as to determine whether further sanction and direction is warranted.

The Alberta Lacrosse Association Discipline and Appeals Committee may sanction any other Team Official of that team which refuses to start play in a manner determined by that Committee, but only after conducting a hearing in accordance with the Bylaws of the Alberta Lacrosse Association

21.02.23 THIRD GAME MISCONDUCT IN ONE SEASON: a two game suspension and referral to the Committee which may further suspend although the individual has finished the two (2) game suspension and resumed participation in lacrosse

21.03 If the penalty resulting in the automatic suspension is incurred in a tournament (other than the Club team Provincials) then the individual shall be suspended from participating in the applicable number of remaining tournament games and those games shall count toward the automatic suspension. The Tournament suspension if not fully served shall carry forward into regular season and/or league/provincial playoff games only.

REGULATION 22 - AUTOMATIC AND OTHER SUSPENSIONS (WOMEN'S FIELD)

22.01 If Player A is disqualified from Game 2 because of a red card received in Game 1, and Game 2 is suspended because of weather, etc., Player A may not participate in the completion of Game 2 no matter how much later in the tournament the game is played to completion. They may play in Game 3 if it is played before the completion of Game 2.

22.02 If Player A is disqualified during the play of Game 2 because of a red card received in Game 2, and Game 2 is suspended because of weather, etc., Player A may not play in Game 3 and they may not play in the completion of Game 2 no matter how much later in the tournament that game takes place.

22.03 If Player A is disqualified during the play of Game 3 because of a red card received in Game 3, and her previous game, Game 2, was suspended because of weather, etc., Player A may play in the completion of Game 2 even if it occurs immediately after Game 3. They may not participate in Game 4.

22.04 If Player A is disqualified from Game 2 because of a red card received in Game 1, and Game 2 is suspended because of weather, etc., but not played to completion by mutual agreement of the coaches, Player A does not have to sit out any additional time in Game 3. Game 2 is considered an official game and their suspension has been served. All stats from a suspended game (goals, team cards, etc.) should carry over from one part of a game to another even if it is played on a separate day.

REGULATION 23- ABUSE BY FANS

23.01 ABUSE BY FANS, as perceived by a referee, Tournament Chair, or the ALA Representative, will result in having the referee have the coach ask their "fan" to immediately remove themselves from the arena/field and not to return for the remainder of the game. The game will not resume until the offending fan or fans are completely removed from the arena/field. If the fan refuses to leave within a reasonable time, the team to which the fan is related will forfeit the game. Such removal and/or forfeit shall be noted on the game sheet and an official game report shall be forwarded to the local governing body.

23.02 Any person who enters into acrimonious discussions, makes abusive or obscene comments or gestures, or threats to referees, the league or tournament RIC, the tournament chair/representative, minor officials, or ALA/LGB staff, shall be fined a minimum of \$100 and suspended for a minimum of two (2) games. The incident shall be reviewed by the ALA Discipline committee to determine if further action is warranted.

REGULATION 24 – DISCIPLINE

- 24.01** Many lacrosse people perform multiple roles, ie: a person may coach, play (box and field), referee, and/or administer. Therefore, any suspensions apply solely to the role that the person was performing when an offence was committed. For example, a suspension to a box player does not extend to field lacrosse, or a suspension to a coach does not extend to their playing status. In the event that an association believes that the offence was serious enough to warrant additional discipline (ie: a suspension on all ALA sanctioned lacrosse activities) then a request to send the case to the ALA Executive Committee.
- 24.02** Coach suspensions must be served on the team that offence occurred on and not permitted to coach on any other team until the suspension is fulfilled unless the coach is suspended the last game of the season or has a suspension carrying over to the next season
- 24.03** Coaches suspended in the previous season must serve the suspension on one team that the coach is assigned to in the following season.

REGULATION 25 - COACHING CERTIFICATION REQUIREMENTS

- 25.01** Each team in Field and Box lacrosse shall comply with CLA Minimum Standards for coaches. In order to be eligible to coach, all coaches must meet the requirements of the ALA Minimum Standards as applicable to each discipline of lacrosse.
- 25.02** In all games (including regular league, playoffs, exhibition, tournaments), teams are required to have all bench personnel who are on the bench meet the CLA Minimum Standards. In practices, teams are required to have at least one of the supervising coaches trained as per CLA Minimum Standards.
- 25.03** In all games for League, Provincials, Alberta Summer Games, and games sanctioned on travel permits, teams are required to have all bench personnel who are on the bench meet the CLA Minimum Standards.
- 25.04** Bench personnel are determined as per ALA Registration system for each team (as per Regulation 6). Only coaches with appropriate training and certified trainers are allowed on the bench.
- 25.05** All Female only teams must have one registered female coach registered to the team in RAMP and on the bench as per the ALA Registration system and correlating to the game sheet.(due to COVID this regulation is suspended for 2021)
- 25.06** All coaches must be 16 years of age in the year he/she wishes to attend a coaching clinic and coach an ALA sanctioned team.
- 25.07** Challenges at the Community Development level are not permitted.
- 25.08** All workbooks required after attending a NCCP clinic must be completed by March 1 of the following year. Coaches who have not completed the workbook by their deadline are suspended until the workbook as passed the CLA grading process.

- 25.09** CLA Minimum standards will be verified by the ALA Office upon request.
- 25.10** Coaches not meeting the Minimum CLA Standard will be suspended for the following year from coaching until the required criteria have been met.
- 25.11** All coaching clinic requests are to be submitted to the ALA office by November 1 yearly by the local governing body. Late submissions will not be considered.
- 25.12** Minimum attendance of twelve (12) coaches is required to hold a clinic. Exceptions may be permitted as approved by the Director of Development.

REGULATION 26 - TRAINER CERTIFICATION REQUIREMENTS

- 26.01** Trainers must have the appropriate certification. Appropriate certification is defined as one of the following:
- a) Any St. John Ambulance Emergency First Aid course of 8 hours (or more) or equivalent
 - b) Canadian Red Cross Standard First Aid & First Responder
 - c) Canadian Red Cross Sport First Responder and Sport Aid course
 - d) Hockey Canada Safety Program (HCSP)
 - e) An appropriate designation (examples: MD; RN; Physiotherapist, Police Officer; Firefighter, Chiropractor; Registered Massage Therapist).

From the above, please be clear CPR (as a stand-alone certification) is NOT an equivalency.

- 26.02** The ALA recognizes only one trainer per team on the bench to address those specific activities (activities which would not include coaching athletes).

REGULATION 27 - PROVINCIAL PLAYOFF REGULATION

- 27.01** The ALA reserves the right to place teams in the classification and series deemed to be in the best interest of the ALA.

REGULATION 28– ALA MINOR BOX PROVINCIALS/ALA TOURNAMENTS/DAVID FEHR CLASSIC REGULATION

28.01 General Policy

- 28.01.1 All participants shall abide by all Canadian Lacrosse Association Rules of Box Lacrosse.
- 28.01.2 The Canadian Lacrosse Association’s Coaches Code and the CLA Coaching Philosophy for Minor Lacrosse must be adhered to. Adherence to these guidelines will be monitored and interpreted by the Director High Performance or designate. The decision of the ALA Director of High Performance will be final.
- 28.01.3 Local Governing Bodies, Clubs, or Member teams, wishing to participate in Provincial tournaments MUST register using the “Provincial Championship Intent Form” to participate along with a \$750.00 Provincial Championship intent fee per team by the date indicated on the Intent Form. If the Local Governing Body, Club, or team fails to provide representation

after submitting an intent at the Provincial Championship then the intent fee will be forfeited and the club will be fined \$ 2000.

28.01.4 16U teams are not required to submit an intent form as all teams in the 16U League are mandated to attend the Provincial Championship competition. The Provincial Championship fee of \$750 is due June 1.

28.01.5 All provincial divisions require two (2) teams that are recognized by the ALA.

28.01.6 Competition intent fees are due to the ALA office by June 1.

28.02 Team Qualification

28.02.1 All teams participating in Provincial Championships/ ALA Tournaments/David Fehr Classic must be registered with the ALA registration system. The player rosters and bench personnel for the Provincial Championship/ALA Tournaments/David Fehr Classic will be those that are registered with the ALA, as per the ALA registration system.

28.02.2 Teams may affiliate to a maximum of 15 players and 2 goalies. Any affiliate goaltenders must be dressed as goaltenders, on the bench, and will only be eligible to participate as a goaltender during Provincials. Teams may carry a maximum of two goalies. ALL affiliates must be drawn from the same club and in a lower division or lower tiered team in the applicable division competing. Tyke teams are permitted to affiliate first year aged tyke players.

28.02.3 Clubs teams without a division below or all teams in the club in the division or level below are attending provincials may affiliate to another team in their Local Governing Body. Players may not be affiliated if a conflict with their normal team exists. All players' first obligation is to their regular club team.

28.02.4 All changes must be approved by ALA Office/tournament representative 72 hours prior to the first game of the applicable Provincial Championship/Tournament.

28.02.5 Suspended players cannot be affiliated. If suspended, as an affiliate player, the suspension must be served with the players original ALA Registered Team.

28.02.6 Teams leaving players at home for affiliated players will forfeit all provincial games and the head coach will be referred to discipline.

28.02.7 There are NO exceptions to the affiliation regulation.

28.02.8 Local Governing Bodies who do not have a recognized league must register these teams with the ALA to qualify to participate in the Provincial Championship Tournament. Intent fees are due to the ALA office by June 1.

28.02.9 All tournament formats are to be approved by the ALA Director of High Performance. The preferred format will be Round Robin.

28.03 Final Standings Tie Break Formula

28.03.1 In the event of a tie in point standings in a competition, final standings shall be determined as follows:

28.03.2 If two teams are tied, the winner of the game or games between the two teams advances. If a tie still exists, the goal average formula listed below will be used.

28.03.3 If three or more teams are tied, and if one team has defeated the other teams with which it is tied after round robin play, that team shall advance.

Otherwise GOAL AVERAGE FORMULA: Only the goals scored in games between the tied teams are used in the goal average formula for tie breaking. Team with the highest ratio advances

28.03.4 Otherwise GOALS AVERAGE FORMULA: Only the goals scored in games between each other plus common opponents are used in the goal average formula for tie breaking. The team with the highest ratio advances.

28.03.5 Otherwise GOALS AGAINST FORMULA: Using goals for and against in all games played by the tied teams.

$$\frac{\text{GOALS FOR}}{\text{GOALS FOR} + \text{GOALS AGAINST}}$$

28.03.6 The formula is applied once to rank all tied teams

28.04 Player Eligibility

All players must be duly registered with the ALA registration databank and listed on the team's roster, for the current year. Overaged players are not permitted to participate in provincials/tournaments unless the player has approval by the ALA Executive by May 1. Leagues approving overaged players MUST have parents sign a waiver and witnessed by a league representative confirming they understand participation in tournaments and provincials is prohibited.

28.05 Coach and Trainer Eligibility

28.05.01 All coaches must be duly registered as coaches with the ALA registration databank for the current year.

28.05.02 All Trainers must be duly registered as trainers with the ALA registration databank for the current year.

28.05.03 All Coaches must meet CLA Coaching Standards.

28.05.04 All trainers must meet ALA Standards as per ALA Regulations,

28.06 Playing Area

Only ALA authorized coaching/trainer personnel, player personnel, officials, LGB representatives and the ALA representative are permitted in the dressing room, bench area and playing surface during game play.

28.07 Minor Box Rules

All teams or Associations that host a Provincial Tournament within the Province of Alberta will comply with the rules set out as follows.

Minor Box Playing Rules

- a) The Canadian Lacrosse Association Rules of Box Lacrosse apply with the exception of punishments for infractions of the rules where those punishments are by ALA Rules more severe than the CLA's.
- b) The Canadian Lacrosse Association's Coaches Code and the CLA Coaching Philosophy for Minor Lacrosse must be adhered to. Adherence to these Guidelines will be monitored and interpreted by the ALA Representative.
- c) All games will start on time unless otherwise decided upon by the ALA Representative.

WARM UP: there will be a three (3) minute warm-up before game time.

- e) Game Times:

10U games will be three (3) fifteen minute runtime periods, no clock stoppage (1 hr time allowance).

12U games will be two (2) fifteen minute and one (1) twenty minute (20) stop time periods, (1.25 hr time allowance).

14U and 16U games will be three (3) twenty minute (20) stop time periods (1.5 hr time allowance).

If a goal differential of six (6) or more goals is present at anytime during the game, at the next whistle to start play, the clock will run at straight time. If the goal differential is brought within four (4) goals, the clock shall return to stop time at that time.

- f) The 30-second clock will be in effect for all minor levels
- g) **STRAIGHT TIME PENALTIES:** a two (2) minute penalty running time, to start at start of play (whistle).
- h) **STOP TIME:** the clock will stop only when: 1. A penalty is called, 2. A face-off takes place, 3. A goal is scored, or 4. A referee signals for the clock to stop.
- i) There will be a three (3) minute rest period between periods
- j) **HOME** teams must be prepared to change their jersey if asked to do so by the Referee.
- k) **SHOT CLOCK:** will be operated by an ALRA official; **TIME KEEPER** will be provided by the **HOME** team; the **SCOREKEEPER** will be provided by the **VISITOR**; and both will provide penalty box personnel.
- l) **OVERTIME:** all games are to be played out (including round robin).
- m) In Round Robin there will be five (5) minute sudden victory periods until a goal is scored. There will be one (1) minute rest period between each five (5) minute period.
- n) In Medal games only as per CLA. Rule 20: exception is made to rest time between periods, which will be (5) minutes.

- o) All games are to be played out (including round robin). TWO points for a win and ZERO points for a loss are awarded.

28.08 Discipline at ALA Provincials/ ALA Tournaments/ David Fehr Classic

28.08.1 General

See Bylaw 10, and Regulation 21

28.08.2 Procedures

The ALA Representative/Tournament Representative will adhere to and interpret the ALA Bylaws and Regulations.

28.08.3 Appeals

To place an appeal, with the Provincials/Tournament/ David Fehr Classic Discipline Committee, the appealing team must put a \$300 non-refundable fee forward. The appeal must be made in writing and must be received no later than 30 minutes after the conclusion of the game. If game conclusion time is missing from the game sheet the scheduled game time conclusion shall be used. If the appeal is won, the fee will be refunded. If any game or portion thereof is to be replayed. The decision of the Provincials/Tournament/ David Fehr Classic Discipline Committee is final unless the sanction carries beyond the tournament.

28.09 ALA Representative

In the regulations for Provincial Championship/David Fehr Classic Tournaments, the ALA Representative will be that person who is appointed by the Director of High Performance.

28.10 Tournament Representative

In the regulations, the Tournament Representative will be that person who is appointed by the host club.

28.11 Provincial Trophies

Provincial Trophies are to be returned to the ALA office by the ALA AGM of the competition year at the club's cost. Clubs failing to return trophies by the deadline will be fined \$250 per month to the replacement value of the trophy which there is no appeal. Damaged trophies will be invoiced to LGB.

REGULATION 29 – ALA MEN'S FIELD PROVINCIAL INVITATIONAL TOURNAMENT/ ALA SANCTIONED TOURNAMENTS

29.01 General Policy

29.01.1 All participants shall abide by all Canadian Lacrosse Association Rules of Field Lacrosse.

29.01.2 The Canadian Lacrosse Association's Coaches Code and the CLA Coaching Philosophy for Minor Lacrosse must be adhered to. Adherence to these guidelines will be monitored and interpreted by the Director of High Performance. The Director of High Performance decision will be final.

- 29.01.3 Member teams wishing to participate in Provincial tournaments MUST register using the “Provincial Invitational Participation Form” to participate along with a \$300.00 Provincial Invitational intent fee per team by July 31. Out of Province teams will submit a \$500 fee. If the Member team fails to provide representation at the Provincial Invitational Tournament then the intent fee will be forfeited and the club fined \$2000.

29.02 Team Qualification

- 29.02.1 All ALA teams participating in Provincial Invitationals Tournament/ Tournaments must be registered with the ALA registration system. The player rosters and bench personnel for the Provincial Invitational Tournament/ tournaments will be those that are registered with the ALA, as per the ALA registration system. Teams participating from another Member Association must have an approved travel permit from their Member Association.
- 29.02.2 All teams participating in Provincial tournament/ tournaments must provide the ALA/tournament representative with rosters for verification and approval of affiliates 72 hours prior to the commencement of the first game of the Provincial Tournament/ tournaments. Submitted rosters will be frozen at that time.
- 29.02.3 All rosters and player identification must be readily available at all provincial tournament games.
- 29.02.4 Teams can have a maximum of 23 players (including goalies) on their roster. Teams must have a minimum number of 12 players to participate.
- 29.02.5 Teams may affiliate to a maximum of 15 players and 2 goalies. Any affiliate goaltenders must be dressed as goaltenders, on the bench, and will only be eligible to participate as a goaltender during Provincials. Teams may carry a maximum of two goalies. ALL affiliates must be drawn from the same club and in a lower division or lower tiered team in the applicable division competing. Tyke teams are permitted to affiliate first year aged tyke players.
- 29.02.6 Clubs teams without a division below or all teams in the club in the division or level below are attending provincials may affiliate to another team in their Local Governing Body. Players may not be affiliated if a conflict with their normal team exists. All players’ first obligation is to their regular club team.
- 29.02.7 A player may not play for more than one team per division in Provincial Tournaments/ tournaments event in a given year.
- 29.02.8 All provincial tournament formats are to be approved by the Director of High Performance. The preferred format will be Round Robin with a playoff. If there are only two teams entered in a Division the preferred format is a best of three series.

29.03 Final Standings Tie Break Formula

- 29.03.1 In the event of a tie in point standings in a competition, final standings shall be determined as follows:
- 29.03.2 If two teams are tied, the winner of the game or games between the two teams advances. If a tie still exists, the goal average formula listed below will be used.
- 29.03.3 If three or more teams are tied, and if one team has defeated the other teams with which it is tied after round robin play, the team shall advance.

Otherwise GOAL AVERAGE FORMULA: Only the goals scored in games between the tied teams are used in the goal average formula for tie breaking. The team with the highest ratio advances

29.03.4 Otherwise GOALS AVERAGE FORMULA: Only the goals scored in games between each other plus common opponents are used in the goal average formula for tie breaking. The team with the highest ratio advances.

29.03.5 Otherwise GOALS AGAINST FORMULA: Using goals for and against in all games played by the tied teams

$$\frac{\text{GOALS FOR}}{\text{GOALS FOR} + \text{GOALS AGAINST}}$$

29.03.6 The formula is applied once to rank all tied teams

29.04 Player Eligibility

All Alberta players must be duly registered with the ALA registration databank and listed on the team's roster, for the current year. Overaged players are not permitted to participate in provincials/tournaments unless the player has approval by the ALA Executive by July 15. The league approving overaged players MUST have parents sign a waiver and witnessed by a league representative confirming they understand participation in tournaments and provincials is prohibited.

29.05 Coach and Trainer Eligibility

29.05.01 All coaches must be duly registered as coaches with the ALA registration databank for the current year.

29.05.02 All Trainers must be duly registered as trainers with the ALA registration databank for the current year.

29.05.02 All Coaches must meet CLA Coaching Standards.

29.05.03 All trainers must meet ALA Standards as per ALA Regulations,

29.06 Men's Field Tournament Rules

All teams or Associations that host a Provincial Tournament within the Province of Alberta will comply with the rules set out as follows.

29.06.1 Field Playing Rules

- a) The Canadian Lacrosse Association Rules of Field Lacrosse apply.
- b) The Canadian Lacrosse Association's Coaches Code and the CLA Coaching Philosophy for Field Lacrosse must be adhered to. Adherence to these Guidelines will be monitored and interpreted by the ALA Representative.
- c) All games will start on time unless otherwise decided upon by the ALA Representative.
- d) WARM UP: there will be a five (5) minute warm-up before game time.

- e) Game Times: full games will be run consisting of 4-15 minute quarters with the exception of the Novice division which will be 2-25 minute halves.
- f) Overtime: after a 5 minute rest, team will switch ends and the game will continue until the first sudden victory goal. Overtime periods will be 4 minute stop time periods with 2 minute rest in between
- g) A game is considered complete if 80% of the game time has elapsed.
- h) An interrupted game will restart at the point of the interruption.
- i) If the Round Robin portion of the Provincial Championships was not completed due to weather related closures or cancellations, then the tournament will be cancelled and no medals will be awarded.
- j) If the Round Robin portion of the Provincial Championships was completed, then the standing will be determined by the round robin games completed. The Tie Break formula will apply.

29.07 Discipline at Provincials/ ALA Tournaments

29.07.1 General

See Bylaw 10

29.07.2 Procedures

- a) The ALA Representative/Tournament representative will adhere to and interpret the ALA Bylaws and Regulations.

29.07.3 Appeals

To place an appeal, with the Provincials/ Tournament Discipline Committee, the appealing team must put a \$300 non-refundable fee forward. The appeal must be made in writing and must be received no later than 30 minutes after the conclusion of the game. If game conclusion time is missing from the game sheet the scheduled game time conclusion shall be used. If any game or portion thereof is to be replayed, the refund will be given after that conclusion. The decision of the Provincials/ Tournament Discipline Committee is final unless the sanction carries beyond the tournament.

29.08 ALA Representative

In the regulations for Provincial Tournaments, the ALA Representative will be that person who is appointed by the Director of High Performance.

29.09 Tournament Representative

In the regulations, the Tournament Representative will be that person who is appointed by the host club.

29.10 Provincial Trophies

Provincial Trophies are to be returned to the ALA office by the ALA AGM of the competition year at the club's cost. Clubs failing to return trophies by the deadline will be fined \$250 per month which there is no appeal. Damaged trophies will be invoiced to LGB.

29.11 Provincial Categories

U10 to U16 will strive to create an A and B provincials where team numbers allow. By July 31st associations will complete the Provincial Invitational Tournament Declaration form summarizing the number of A teams and B teams that each association will send to the tournament. A minimum of two teams per division are required for play to occur for the provincial championships. The maximum number of teams allowed at each age division will be determined by the host organization.

- 29.11.1 Clubs entering two (2) teams or more in a division must ensure these teams are parity teams.

REGULATION 30 – WOMEN’S FIELD LACROSSE PROVINCIAL INVITATIONAL TOURNAMENT/ALA SANCTIONED TOURNAMENTS

30.01 General Policy

- 30.01.1 All participants shall abide by all World Lacrosse Rules of Women’s Field Lacrosse.
- 30.01.2 The Canadian Lacrosse Association’s Coaches Code and the CLA Coaching Philosophy for Minor Lacrosse must be adhered to. Adherence to these guidelines will be monitored and interpreted by the Director of High Performance. The ALA Director of High Performance decision will be final.
- 30.01.3 Member teams wishing to participate in Provincial tournaments MUST register using the “Provincial Invitational Participation Form” to participate along with a \$200.00 Provincial Invitational intent fee per team by July 31. Out of Province teams will submit a \$400 fee. If the Member team fails to provide representation at the Provincial Invitational Tournament then the intent fee will be forfeited and the club fined \$2000.

30.02 Team Qualification

- 30.02.1 All ALA teams participating in Provincial Invitationals Tournament/ tournaments must be registered with the ALA registration system. The player rosters and bench personnel for the Provincial Invitational Tournament / tournaments will be those that are registered with the ALA, as per the ALA registration system. Teams participating from another Member Association must have an approved travel permit from their Member
- 30.02.2 All teams participating in Provincial tournament/ tournaments must provide the ALA/tournament representative with rosters for verification and approval of affiliates 72 hours prior to the commencement of the first game of the Provincial Tournament/ tournament. Submitted rosters will be frozen at that time.
- 30.02.3 All rosters and player identification must be readily available at all provincial tournament/tournament games.
- 30.02.4 Teams can have a maximum of 18 players (including goalies) on their roster. Teams must have a minimum number of 12 players to participate.
- 30.02.5 Teams may affiliate to a maximum of 15 players and 2 goalies. Any affiliate goaltenders must be dressed as goaltenders, on the bench, and will only be eligible to participate as a goaltender during Provincials. Teams may carry a maximum of two goalies. ALL affiliates must be drawn from the same club and in a lower division or lower tiered team in

the applicable division competing. Tyke teams are permitted to affiliate first year aged tyke players.

- 30.02.6 Clubs teams without a division below or all teams in the club in the division or level below are attending provincials may affiliate to another team in their Local Governing Body. Players may not be affiliated if a conflict with their normal team exists. All players' first obligation is to their regular club team.
- 30.02.7 A player may not play for more than one team per division in Provincial Tournament/ tournament event in a given year.
- 30.02.8 All Provincial tournament formats are to be approved by the Director of High Performance. The preferred format will be Round Robin with a playoff. If there are only two teams entered in a Division the preferred format is a best of three series.

30.03 Final Standings Tie Break Formula

- 30.03.1 In the event of a tie in point standings in a competition, final standings shall be determined as follows:
 - 30.03.2 If two teams are tied, the winner of the game or games between the two teams advances. If a tie still exists, the goal average formula listed below will be used.
 - 30.03.3 If three or more teams are tied, and if one team has defeated the other teams with which it is tied after round robin play, the team shall advance.

Otherwise GOAL AVERAGE FORMULA: Only the goals scored in games between the tied teams are used in the goal average formula for tie breaking. Team with the highest ratio advances
 - 30.03.4 Otherwise GOALS AVERAGE FORMULA: Only the goals scored in games between each other plus common opponents are used in the goal average formula for tie breaking. The team with the highest ratio advances.
 - 30.03.5 Otherwise GOALS AGAINST FORMULA: Using goals for and against in all games played by the tied teams

$$\frac{\text{GOALS FOR}}{\text{GOALS FOR} + \text{GOALS AGAINST}}$$

- 30.03.6 The formula is applied once to rank all tied teams

30.04 Player Eligibility

All Alberta players must be duly registered with the ALA registration databank and listed on the team's roster, for the current year. Overaged players are not permitted to participate in provincials/tournaments unless the player has approval by the ALA Executive by July 15. The league approving overaged players MUST have parents sign a waiver and witnessed by a league representative confirming they understand participation in tournaments and provincials is prohibited.

30.05 Coach and Trainer Eligibility

- 30.05.01 All coaches must be duly registered as coaches with the ALA registration databank for the current year.
- 30.05.02 All Trainers must be duly registered as trainers with the ALA registration databank for the current year.
- 30.05.02 All Coaches must meet CLA Coaching Standards.
- 30.05.03 All trainers must meet ALA Standards as per ALA Regulations,

30.06 Women's Field Tournament Rules

Provincial Tournament/tournaments within the Province of Alberta will comply with the rules set out as follows.

30.06.1 Women's Field Playing Rules

- a) The World Lacrosse Rules of Field Lacrosse apply. NCAA Crosses will be permitted
- b) The Canadian Lacrosse Association's Coaches Code and the CLA Coaching Philosophy for Field Lacrosse must be adhered to. Adherence to these Guidelines will be monitored and interpreted by the ALA Representative.
- c) All games will start on time unless otherwise decided upon by the ALA Representative.
- d) WARM UP: there will be a five (5) minute warm-up before game time.
- e) Game Times: Full games will be run consisting of 2 – 25 minute halves with a 5 minute half time rest. Teams will have one (1) two-minute timeouts per game. The clock shall only stop in the event of injury. Injured players must leave the field until the next scheduled substitution and shall be replaced by another player.
- f) Overtime: after a 5 minute rest, team will switch ends and the game will continue until the first sudden victory goal. Overtime periods will be 6 minute stop time periods with 3 minute rest in between.
- g) A game is considered complete if 80% of the game time has elapsed.
- h) An interrupted game will restart at the point of the interruption.
- i) If the Round Robin portion of the Provincial Championships was not completed due to weather related closures or cancellations, then the tournament will be cancelled and no medals will be awarded.
- j) If the Round Robin portion of the Provincial Championships was completed, then the standing will be determined by the round robin games completed. The Tie Break formula will apply.

30.07 Discipline at Provincials/Tournaments

30.07.1 General

See Bylaw 10, Regulation 22

30.07.2 Procedures

- a) The ALA Representative/tournament representative will adhere to and interpret the ALA Bylaws and Regulations.

30.07.3 Appeals

To place an appeal, with the Provincials/Tournament Discipline Committee, the appealing team must put a \$300 non-refundable fee forward. The appeal must be made in writing and must be received no later than 30 minutes after the conclusion of the game. If game conclusion time is missing from the game sheet the scheduled game time conclusion shall be used. If any game or portion thereof is to be replayed, the refund will be given after that conclusion. The decision of the Provincials/Tournament Discipline Committee is final unless the sanction carries beyond the tournament.

30.08 ALA Representative

In the regulations for Provincial Championships, the ALA Representative will be that person who is appointed by the Director of High Performance.

30.09 Tournament Representative

In the regulations, the Tournament Representative will be that person who is appointed by the host club.

30.10 Provincial Trophies

Provincial Trophies are to be returned to the ALA office by the ALA AGM of the competition year at the club's cost. Clubs failing to return trophies by the deadline will be fined \$250 per month which there is no appeal. Damaged trophies will be invoiced to LGB.

30.10 Provincial Categories

Clubs entering two (2) teams or more in a division must ensure these teams are parity teams.

REGULATION 31 – MAJOR BOX PROVINCIALS

31.01 Major box Provincial Championships will be conducted as per ALA and RMLL rules and policy.

31.02 All Schedules complete with dates, time, and location are to be approved by the ALA Director of High Performance.

31.03 All contracts for Major Lacrosse Provincials must be in the name of Alberta Lacrosse unless approved by the Executive Director.

31.04 Player Eligibility

All Alberta players must be duly registered with the ALA registration databank and listed on the team's roster, for the current year. Any visiting teams must be registered and in good standing with their provincial organizations for the current year.

31.05 Coach and Trainer Eligibility

31.05.01 All coaches must be duly registered as coaches with the ALA registration databank for the current year.

31.05.02 All Trainers must be duly registered as trainers with the ALA registration databank for the current year.

31.05.02 All Coaches must meet CLA Coaching Standards.

31.05.03 All trainers must meet ALA Standards as per ALA Regulations.

31.05.04 Coaches and Trainers are as per the ALA Registration system.

31.06 ALA Representative

In the regulations for Provincial Major Lacrosse Championships, the ALA Representative will be the division commissioner. If the division commissioner is unable to attend, the ALA representative will be the person who is appointed by the Director of High Performance.

31.07 Provincial Trophies

Provincial Trophies are to be returned to the ALA office by the RMLL AGM of the competition year at the team's cost. Teams failing to return trophies by the deadline will be fined \$250 per month to the replacement value of the trophy which there is no appeal. Damaged trophies will be invoiced to LGB.

REGULATION 32– ALBERTA LACROSSE REFEREES ASSOCIATION

32.01 The ALRA

- All lacrosse officials living within the province of Alberta shall be members of the Alberta Lacrosse Referees Association (ALRA) and registered in the ALA Registration system
- The ALRA shall be responsible to recruit, mentor and retain officials.
- The ALRA shall work with the ALA and LGB's to ensure that all lacrosse officials receive the appropriate CLA training as well as ongoing instruction.
- All ALRA Officials who registered and attended a clinic in the previous season may be assigned to game assignments until May 1st
- All ALRA Officials must attend a clinic and successfully complete exam yearly
- The ALRA are responsible to assign referees to all lacrosse games in the province.
- Games will be assigned by the ALRA in the following hierarchy playoff games, regular season games, tournament games and then exhibition games
- The ALRA and each LGB shall jointly select a Referee-in-Chief for the LGB and to sit on the ALRA Board of Directors.

32.02 League Schedules

Once a league schedule or games have been finalized, the LGB (or league if there is no LGB) shall, within two (2) days deliver the schedule to the ALA Office and, in any event, no later than one (1) week before the first game. Failure to comply will result in a fine of \$500.00. There will be no appeal.

Any changes to the schedule must be completed as follows:

- Game cancellations within 24 hours of the scheduled start time of the game (except unneeded playoff games). LGBs will be responsible for the full game fee.
- Game cancellations within 2 weeks of the scheduled start time of the game (including unneeded playoff games). LGBs will be responsible for the full assigning fee.
- Changes to a specific game (time or venue) within 48 hours of the game. Any date changes are considered to be cancellations.
- Any additions to the schedule within 72 hours of the scheduled start time of the game.
- All other notifications will be adhered to by the ALRA

In the event of a sudden and unforeseen circumstance arising related to events reasonably beyond the control of any party (e.g., severe weather, catastrophic damage to the venue, security occurrence, widespread illness, etc.), no fine shall be charged by or be payable to the ALRA.

32.03 Notice to ALRA of Tournament Schedule

Any Member who hosts a tournament shall provide a tournament schedule to the ALRA official, who is the R.I.C. for the tournament, at least Two (2) weeks in advance of the start date of the tournament. Failure to comply will result in a fine of according to the schedule below at the discretion of the ALRA. There will be no appeal.

- \$250 for schedules submitted 10-14 days prior to the tournament.
- For schedules submitted less than 10 days prior to the start of the tournament the greater of \$500 or:
 - \$5 per scheduled game for schedules submitted 7 days prior to the tournament;
 - \$7 per scheduled game for schedules submitted with 6 days prior to the tournament;
 - \$9 per scheduled game for schedules submitted with 5 days prior to the tournament;
 - \$11 per scheduled game for schedules submitted with 4 days prior to the tournament; and
 - For schedules submitted less than 4 days prior to the tournament the ALRA may refuse to schedule referees

32.04 Clubs will be responsible for their teams who withdraw within fourteen (14) days of the start date of the tournament and will be invoiced for fines resulting from schedule changes as per 32.03. Written confirmation of the team attending and withdrawing from the tournament must be provided to the ALA Office prior to fines being levied.

32.05 All ALRA Officials will be assigned using the ALRA approved assignment system. LGB's, clubs or other members may employ a manual form of assigning, but the schedule will be entered into the system at the beginning of the season and all assignments must be entered within two weeks of the conclusion of the season.

32.06 Payment to ALRA

32.06.01 Where the ALRA invoices LGB's for officials the LGB is required to remit, to the ALRA, a 50% deposit of officiating fees (based on the league schedule submitted to the ALA) within 1 week of the start of the season. The remaining 50% is due 30 days after the start of the season. Any reconciliation of officiating expenses including but not limited to playoffs, travel, assigning fees, and per diem will invoice to the LGB within 30 days of the conclusion of the season. The invoice will be due to the ALRA within 30 days of receipt of the ALRA's final invoice.

32.06.02 The ALRA will invoice the RMLL for 50% of the amount of the travel fees of previous year which is due seven (7) business days prior to the start of the season. The balance of the final current end of season invoice is due 30 days after the reconciliation of the final current season invoice.

32.06.03 Where the ALRA invoices Clubs or Teams for tournaments, the Club or Team is required to submit 100% of the estimated invoice two (2) weeks prior to the start of the tournament for the scheduling and game fee amount based on the schedule provided by the host. The final invoice will include travel and RIC fees which will be reconciled with the ALA Member within Ten (10) days of receiving the ALRA's final invoice. Exhibition game invoices are due ten (10) days of receiving the ALRA's invoice.

32.06.04 Where the ALRA invoices Club or Teams for exhibition games, the Club or Team is required to submit 100% of the invoice amount within ten (10) day of receiving the ALRA's invoice.

Invoices outstanding past the allotted times mentioned above may be charged at 24 % per annum.

32.06.05 Game Fees

a) Game Fees for lacrosse officials are as follows:

BOX LACROSSE			
Level	Pay Rate	Scheduling Fee	Total
8U	\$22.00 x 2 (\$44.00)	\$6.00	\$50.00
10U	\$24.00 x 2 (\$48.00)	\$6.00	\$54.00
12U	\$31.00 x 2 (\$62.00)	\$6.00	\$68.00
14U	\$36.00 x 2 (\$72.00)	\$6.00	\$78.00
16U	\$43.00 x 2 (\$86.00)	\$6.00	\$92.00
3 on 3	\$15.00 x 2 (\$30.00)	\$6.00	\$36.00
4 on 4	\$15.00 x 2 (\$30.00)	\$6.00	\$36.00
Junior Recreational	\$57.00 x 2 (\$114.00)	\$6.00	\$120.00

Jr B Tiers III, Jr Ladies	\$73.00 x 2 (\$146.00)	\$6.00	\$152.00
Jr B Tiers II	\$73.00 x 2 (\$146.00)	\$6.00	\$152.00
Jr B Tiers I Senior C	\$79.00 x 2 (\$158.00)	\$6.00	\$164.00
Junior A	\$85.00 x 2 (\$170.00)	\$6.00	\$176.00
Senior B	\$85.00 x 2 (\$170.00)	\$6.00	\$176.00
Senior Ladies	\$79.00 x 2 (\$158.00)	\$6.00	\$164.00
Masters	\$43.00 x 2 (\$86.00)	\$6.00	\$92.00
Standby Official	½ game fee as indicated		
Scheduling Fee	\$6.00 per game		
FIELD LACROSSE (Traditional 10 on 10)			
Level	Pay Rate	Scheduling Fee	Total
U8	\$21.00 x 2 (\$42.00)	\$6.00	\$48.00
U10	\$21.00 x 2 (\$42.00)	\$6.00	\$48.00
U12	\$23.00 x 2 (\$46.00)	\$6.00	\$52.00
U14	\$26.00 x 2 (\$52.00)	\$6.00	\$58.00
U16	\$32.00 x 2 (\$64.00)	\$6.00	\$70.00
U19	\$39.00 x 2 (\$78.00)	\$6.00	\$84.00
Senior	\$52.00 x 2 (\$104.00)	\$6.00	\$110.00
Standby Official	N/A		
Scheduling Fee	\$6.00 per game		

- b) Officials working in any ALA sanctioned game, combine, or tournament will be provided the same game fee as above unless previously agreed upon by the ALRA Executive.
- c) Officials working any league playoff medal game or ALA Provincial Minor Box or Field medal game are to be compensated at the regular season rate plus 10% per each official's rate per game. Any cancelled games will be subject to a lower assigning fee of \$3.00
- d) On occasion, the ALRA is requested to provide a standby (third) official. The primary purpose of this official is to stand in should one of the other officials be

injured. The official is also responsible for monitoring the 30 second clock, timekeeper and scorekeeper. Should there be a request for a standby official, this official will be paid ½ of the respective per official game fee. The request for the standby official shall come in writing by the requesting team to the local Referee-In-Chief not less than 48 hours prior to the start of the game. The ALRA shall, whenever possible, use local officials for the 'third official' to avoid unnecessary cost to the LGB and Leagues.

- e) Referee in Chief fees for tournaments will be an hourly fee bench marked to the Tyke game fee rate. Mileage and per diem charges apply as per ALA Regulation 32.06.04.

32.06.06 **Mileage**

Mileage will be paid by the ALRA to officials that utilize a personal/private vehicle to get to and from games where they are assigned as an on-floor official (where applicable) under the following guidelines:

- Mileage will be paid to an official who drives to his/her game at a rate of \$0.40 per km when the round-trip distance (to and from the arena that the official is assigned to) is greater than 50 km. When the round trip distance is less than 50km, mileage will not be paid.
- Mileage is not paid in the officials' municipality.
- When the round-trip distance is over 450 km, the travel arrangements must be agreed to by the ALA or the LGB responsible for payment.

32.06.07 **Travel Time**

The ALRA encourages carpooling for all officials. Carpooling is required for mileage over 50 km. (due to COVID this regulation is suspended for 2021) Where carpooling is employed, travel time will be paid under the following guidelines:

- Travel time is only paid to a passenger.
- In situations where two (2) or more officials travel together to officiate at the same venue, travel time will be paid to the officials who are passengers at a rate of \$0.10/km when the round-trip distance (to and from the arena that the official is assigned to) is greater than 50 km.

32.06.08 **Per Diem**

A per diem will apply to referees that are away from home (travelling or refereeing). Referees travelling 200 km or more round trip will receive \$20. Overnight trips will be paid at a rate of \$50 per day

32.07 Selection of Referees for National/International Competitions

- 32.07.01 The ALRA will inform its Members of their consideration for Box Nationals, Field Nationals, or upcoming International Competitions as well as the minimum criteria required for successful applicants for the respective event(s). Those members should then forward their applications to the ALRA.

- 32.07.02 The ALRA will request applications from its Members for Box Nationals, Field Nationals, and upcoming International Competitions upon the conclusion of applicable clinics.
- 32.07.03 The ALRA shall submit a list of applicants, and their respective ALRA ranking, whom are being considered for Box Nationals, Field Nationals, and upcoming International Competitions to the ALA Director of Development by March 15 of the current year.
- 32.07.04 The ALRA will then communicate the list of pre-screened officials and applicants with the ALA Office, ALA Director of Development, and ALA President prior to May 15. The officials under consideration will have their officiating schedules communicated to the ALA Office, ALA Director of Development and ALA President for evaluation of the officials.
- 32.07.05 The ALA Director of Development and ALRA VP of Development will establish the criteria to determine a competent official. The criteria to establish competency may be based on, in ranked order: (1) performance on-floor in the given year; (2) maintaining an acceptable level of athletic performance, as monitored and scored by the ALRA; (3) Commissioner/LGB President recommendation as it relates to applicable Competition; (4) on- and off-floor intangibles; and (5) dedication to assisting the ALRA. The ALA Director of Development will provide feedback on the approved/pre-screened? officials throughout the season via the ALRA VP of Development.
- 32.07.06 A Committee shall be comprised of the ALRA VP Development (Chair), ALRA President, RMLL RIC, the ALA Director of Development, and ALRA League supervisor to select qualified Officials for Box Nationals, Field Nationals, and upcoming International Competitions
- 32.07.07 The National/International Selection Committee will evaluate all of the officials who have applied for each level of Box and Field National/International Competition. Officials who are not working the level of National/International Championship, in the current season will not be considered.
- 32.07.08 The Selection Committee shall provide a list of the Officials, in order of ranking, in consideration for each level of Box Nationals, Field Nationals, and upcoming International Competitions complete with evaluations from the Selection Committee to the ALA office by June 15 of each season. Additional relevant information regarding their on- and off-floor contributions or concerns may be included.
- 32.07.09 The ALA Office will communicate a list of approved candidate(s) for each level of Box Nationals, Field Nationals, and upcoming International Competitions in writing, no later than July 1 of each season. If the list of approved candidates is not mutually agreed upon by the ALA and the ALRA, a revised list, complete with rationale for revisions, will be communicated to the Selection Committee by the ALA Office by June 20 of each season.
- 32.07.10 If agreement on an approved list of candidates is not reached by June 25 of each season, a Selection Review Committee shall be formed. The Committee will be comprised of the ALA President (Chair), ALRA President, and RMLL Division Commissioner/LGB President of the applicable division. The RMLL President shall replace the RMLL Division Commissioner for issues with a recommendation for an official who is to attend an International Box Competition.

- 32.07.11 All approved/pre-screened applicants will be notified as to the outcome of their application by the ALRA's designate.
- 32.07.12 All selections for Box Nationals must officiate the Provincial series at the applicable division. The ALA President and ALRA President may waive this requirement upon application by the official. Requests are to include rational for the exemption. If an Official does not meet the requirement of Officiating the applicable division, and an exemption has not be granted, the next ranked applicant on the list will be contacted as a replacement.

32.08 ALRA Officials Travel

- 32.08.01 The Officials travel permit must be filed with the ALA office 12 hours after the official accepts the assignment for games outside the jurisdiction of the ALA.
- 32.08.02 Approval or disapproval will be given within 3 days after the travel permit has been received. Assigning to ALA games scheduled at the time of the travel permit request takes precedent over officials travel outside of province for non-RMLL games.
- 32.08.03 When an Official applies for a travel permit the Executive Director verifies with ALRA President the Officials credentials and registration is in order. If everything is in order, the Executive Director, then gives conditional approval. The Director of Development then sanctions the travel permit. If the Director has any issues, they must refer the issue to the ALA Executive Committee and ALRA President for discussion and approval or denial of said travel permit.
- 32.08.04 All denied travel permit requests will supply rational for the denial.
- 32.08.05 Any official traveling without proper authorization, or valid travel permit will be referred to ALA Discipline Committee.
- 32.08.06 All Officials from other Member Associations must receive permission from their Member Associations' Executive Director.

32.09 Review of Official's Game Reports

- 32.09.01 As per CLA Rule 23(l), "referees shall report to the appropriate governing body promptly and in detail the circumstances of incidents which are outlined in Rule 23(l). Referees shall use the ALRA's online reporting system for their reports within 24 hours.
- 32.09.02 At any point during this process, if there has been an inaccuracy noted, the inaccuracy should be communicated to the ALRA for reasonable correction or retraction.

32.10 Game Sheets

- 32.10.1 ALA sanctioned games must use ALA game sheet or RMLL Game sheet.
- 32.10.2 Games sheets are required for ALL games.
- 32.10.3 Games sheets are to be completed prior to the game.
- 32.10.4 All games requiring officials must complete games sheets in their entirety and signed off by all officials.

REGULATION 33- ACCOUNTS PAYABLE TO ALA/ALA MEMBERS

- 33.01** Invoices issue by the ALA to Members and Members of Members are net 30 days with the exception of tournament invoices which are net 10 days.
- 33.02** Invoices outstanding past 30 days will be charged an interest rate of 24% per annum.
- 33.03** Members who have invoices outstanding 45 days or more will be deemed Members not in good standing, unless other payment arrangements have been approved by the ALA office with the exception of tournament invoices outstanding 20 days.
- 33.04** Members deemed Members not in good standing will be required to provide the ALA with a bond in the amount of the original 45 day outstanding invoice before that Member is deemed in good standing.
- 33.05** All NSF checks will be charged back in the amount of \$35.00

REGULATION 34 - MEMBERS NOT IN GOOD STANDING

The Alberta Lacrosse Association Executive Committee, at the request of an ALA Member, may declare another Member or Member of Member not in good standing.

REGULATION 35 – ALA AGM PROXY FORMS

- 35.01** The Alberta Lacrosse Association will only accept Proxy Forms completed in their entirety, including but not limited to name of who proxy is assigned to, personal information of head coach and signature of head coach providing the proxy.
- 35.02** All Eligible Proxy Forms must be received by the ALA office 48 hours prior to the start of the AGM.

REGULATION 36 – BODY CORPORATE

- 36.01** All ALA Members must supply submit proof of Corporate Filing and Financial statements yearly to the ALA Office as per Bylaw 2.01.6 180 days following the Members year end. Failure to do so will result in the Member being deemed a Member not in Good Standing.
- 36.02** ALA Minor Lacrosse Members must provide forty five (45) days notice to Major Lacrosse teams when removing the said team from their membership. Removal cannot occur between March 1 and September 15.

REGULATION 37 – RETURN to ACTIVITY - Stage 1

- 37.01** All Participants must be registered in the 2020 Return to Activity Season prior to participating in any ALA sanctioned activities.
- 37.01.1 All participants must sign the COVID-19 waiver
- 37.01.2 Participants with symptoms such as cough, fever, shortness of breath, runny nose, or sore throat symptoms to complete the self-assessment and get tested for COVID-19.

Order 05-2020 legally obligates individuals who have a cough, fever, shortness of breath, runny nose, or sore throat (that is not related to a pre-existing illness or health condition) to be in isolation for 10 days from the start of symptoms, or until symptoms resolve, whichever takes longer.

37.01.3 Participants who are sick with cold-like symptoms such as cough, fever, runny nose, sore throat, or shortness of breath, MUST NOT be in the event.

37.01.4 All participants must comply with the Alberta Lacrosse Association Framework for Return to Activity and Alberta Government Health Orders. Failure to comply will result in a \$5000.00 or the amount of AHS fine, whichever is greater.

37.02 2020 Return to Activity Season is June 1, 2020 to February 28, 2021.

37.03 All sanction requests must come from an ALA Member Club. All events must be sanctioned by the ALA office prior to commencement of event.

37.03.1 All events must track attendance and submit to the ALA Office biweekly.

37.04 All ALA Sanctioned events MUST have at least one Competitive Introduction In training coach or higher training who is 18 years of age. All coaches must meet CLA Minimum Standards for Coaching for applicable age division. All coaches must be duly registered in RAMP. The Competitive Introduction coach is responsible for the adherence of Alberta Lacrosse Association Framework for Return to Activity and Alberta Government Health Orders.

37.05 Overall attendance cannot exceed 50 participants. Only parents and guardians are allowed to spectate in a designated area if limit is not exceeded.

REGULATION 38 – RETURN to SPORT

38.01 All Participants must be registered in the 2020 Return to Activity/Sport Season prior to participating in any ALA sanctioned activities.

38.01.1 All participants must sign the COVID-19 waiver

38.01.2 Participants with symptoms such as cough, fever, shortness of breath, runny nose, or sore throat symptoms to complete the self-assessment and get tested for COVID-19. Order 05-2020 legally obligates individuals who have a cough, fever, shortness of breath, runny nose, or sore throat (that is not related to a pre-existing illness or health condition) to be in isolation for 10 days from the start of symptoms, or until symptoms resolve, whichever takes longer.

38.01.3 Participants who are sick with cold-like symptoms such as cough, fever, runny nose, sore throat, or shortness of breath, MUST NOT be in the event.

38.01.4 All participants must comply with the Alberta Lacrosse Association Framework for Return to Activity and Alberta Government Health Orders. Failure to comply will result in a \$5000.00 or the amount of AHS fine, whichever is greater.

38.02 2020 Return to Activity/Sport Season is June 1, 2020 to February 28, 2021.

38.03 All sanction requests must come from an ALA Member Club. All events must be sanctioned by the ALA office prior to commencement of event.

38.03.1 All events must track attendance and submit to the ALA Office biweekly.

- 38.03.2 All players are to come dressed to the event.
- 38.03.3 Sharing of personal equipment and water bottles is prohibited.
- 38.03.4 Coaches in multiple programs must social distance.
- 38.04** All ALA Sanctioned events MUST have at least one Competitive Introduction In training coach or higher training who is 18 years of age. All coaches must meet CLA Minimum Standards for Coaching for applicable age division. All coaches must be duly registered in RAMP. The Competitive Introduction coach is responsible for the adherence of Alberta Lacrosse Association Framework for Return to Activity and Alberta Government Health Orders.
- 38.05** Cohort groups and mini-leagues cannot exceed 50 participants and only play within the same geographical regions. Cohort groups not social distancing must participate in one cohort group who are not social distancing.
- 38.05.01 50 Participants includes coaches/staff, instructors, participants from multiple teams, officials, and volunteers unable to social distance.
- 38.05.02 Each cohort group or mini-league can be comprised of multiple teams, to a maximum of 50 people. Game play/practice between teams must be limited to teams within the same cohort group/mini-league. Teams in different mini-leagues cannot play each other.
- 38.05.03 At least two-metres distancing should be maintained between all when off the field of play (e.g., on benches, during intermission).
- 38.06** **Box Lacrosse Programming**
- 38.06.01 See Regulation 5.03.5 Recreational Lacrosse.
- 38.06.02 See Regulation 16 Box Lacrosse 4 on 4
- 38.06.03 **3 on 3 Game Play**
- 38.06.3.1 Each team shall be composed of a maximum of six (6) players and one (1) goaltender.
- 38.06.3.2 The game shall be played with three (3) players and one (1) goaltender on the floor for each team.
- 38.06.3.3 Teams will be given a 3-minute warm up prior to each game.
- 38.06.3.4 The duration of the game shall be two 10-minute run time periods, with a 1-minute intermission between periods. Each period shall start with a face-off. The clock shall only stop for an injury.
- 38.06.3.5 No shot clock shall be used. At the referee's discretion, a 10-second verbal warning may be given prior to awarding a change of possession for not advancing to the net.
- 38.06.3.6 There will be no face-off to restart play following a goal. Once a goal is scored, the scoring team must all clear to the center line, as a whole, before re-entering the zone (similar to the LTAD fall-back rule).
- 38.06.3.7 If a ball makes contact with the mesh surrounding the arena, the ball shall be deemed out of bounds' and possession shall be awarded to the non-offending team.

38.06.3.8 There is to be no overtime during regular games. Two (2) points awarded for a win. One (1) point for a tie. Zero points for a loss.

38.06.3.9 In semi-final and final games: If a tie occurs, a shootout will decide the winner:

- a) Each team shall select 3 shooters
- b) Each team shall alternate equal chances to score
- c) If tied after all 6 initial shooters attempt to score, teams will alternate single attempts to determine the winner in sudden victory on equal chances.
- d) Shooters may not be repeated until all players have attempted to score in the shoot out

38.06.3.10 **Penalties**

38.06.3.11 All penalties in the CLA Rulebook shall apply.

38.06.3.12 Minor penalties shall result in a single penalty shot. For any penalty committed, after the penalty shot, regardless of the outcome of the penalty shot, possession will be awarded to the team who took the penalty shot.

38.06.3.13 Double minor penalties shall result in two penalty shots, player remains in the game. For any double minor penalty committed, after the penalty shots, regardless of the outcome of the penalty shots, possession will be awarded to the team who took the penalty shot.

38.06.3.14 Major penalties shall result in a penalty shot and a game misconduct. For any penalty committed, after the penalty shot, regardless of the outcome of the penalty shot, possession will be awarded to the team who took the penalty shot.

38.06.3.15 10-minute misconducts shall result in an expulsion for the remainder of the game, not to carry to the next game.

38.06.3.16 Fighting, Match Penalties, and Gross Misconduct penalties shall result in a penalty shot, and expulsion from the event. For any penalty committed, after the penalty shot, regardless of the outcome of the penalty shot, possession will be awarded to the team who took the penalty shot.

38.06.3.17 Game Reports shall be electronically filed for all penalties listed under CLA Rule 23(L), as well as any incidents of fighting.

38.06.3.18 Any player receiving three (3) penalties in one game shall receive an expulsion for the remainder of the game, not to carry to the next game. A double minor shall count as two (2) penalties toward the maximum of three (3).

38.06.3.19 Any player who receives two (2) game expulsions for exceeding three (3) penalties shall be suspended for the remainder of the event.

38.07 Men's Field and Women's Field Lacrosse Programming

38.07.01 See Regulation 5.03.5 Recreational Lacrosse

38.07.02 **U8 Play will consist of 4 on 4** - (MF/WF 3 field players and a goalie). 4x4 nets will be used.

**No Long Poles*

38.07.02 Playing Surface - The playing field shall be rectangular, 60-70 yards max in length and 35-45 yards in width. The playing field shall be rectangular, 60-70 yards max in length and 35-45 yards in width. The center of the field shall be marked by approximately a four-inch circle, square or X. The goal creases shall be circular and painted on the field with a radius of 9 feet. Portable creases can also be used instead of painted creases.

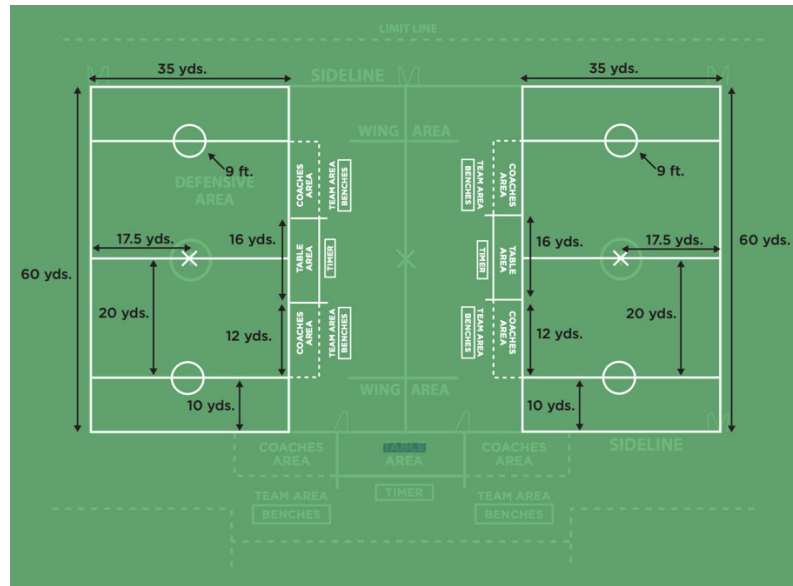

- 38.07.02.3 Play will be non-contact with no offsides and no faceoffs after goals.
- 38.07.02.4 Players will be subbed out for fouls as there are no time served fouls.
- 38.07.02.5 Play will NOT include offsides and will NOT include draws after goals
- 38.07.02.6 A competition will consist of two 12-minute running time halves, with a 4-minute halftime period.
- 38.07.03 **U10+ Play will consist of 7 on 7 play** (MF- 2 attack, 2 midfield, 2 long poles, 1 goalie) (WF- 6 field players, 1 goalie. 6 x 6 nets will be used).

**Only three (3) long poles permitted on the field at one time in MF*

38.07.03.1 Playing Surface - The playing field shall be rectangular, 60-70 yards max in length and 35-45 yards in width. The playing field shall be rectangular, 60-70 yards max in length and 35-45 yards in width. The center of the field shall be marked by approximately a four-inch circle, square or X. The goal creases shall be circular and painted on the field with a radius of 9 feet. Portable creases can also be used instead of painted creases.

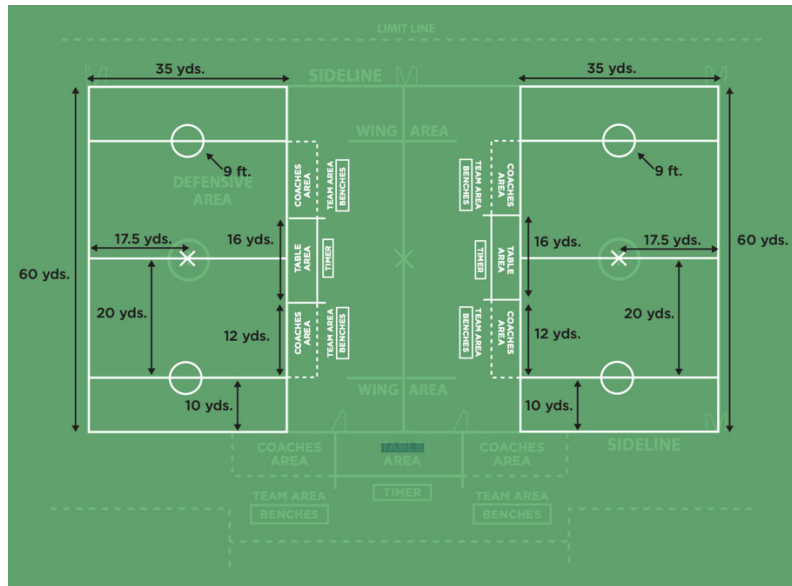

38.08 Hybrid Box Lacrosse and Field Lacrosse Programming

- 38.08.01 The Hybrid Box Lacrosse and Field Lacrosse programming will keep the same cohort group together for the duration of the program offering box and field lacrosse.
- 38.08.01 See Regulation 5.03.5 Recreational Lacrosse
- 38.08.02 See Regulation 16 Box Lacrosse 4 on 4
- 38.08.03 See Regulation 38.06 Box Lacrosse
- 38.08.04 See Regulation 38.07 Men's Field and Women's Field Lacrosse

38.09 Major Box Lacrosse Programming

- 38.09.01 See Regulation 5.03.5 Recreational Lacrosse
- 38.09.02 See Regulation 16 Box Lacrosse 4 on 4
- 38.09.03 See Regulation 38.06

REGULATION 39 – CAMP SANCTIONING

The Alberta Lacrosse Association is dedicated to player development. Co-operation with Member and Non-Member Lacrosse Camp Organizers by promotion and sanctioning of Camps. This sanction process is for camps and not for league programs.

- 39.01** All camps sanctioned by the ALA must be open to all ALA Members.
- 39.02** All camps sanctioned must not compete with ALA or ALA Member Club programming.
- 39.03** All camps sanctioned by the ALA must have all instructors/coaches adequately trained as per CLA Minimum Coaching Standards for the 14U age division. List of all instructor/coaches MUST be supplied.

- 39.04** New player camps operating more than three (3) days must register players who were not registered with the ALA the previous regular season in RAMP. ALA Registration fees will apply.
- 39.05** Entities must be registered as a Body Corporate.
- 39.06** ALA Members cannot request camp sanctions for non-ALA members.
- 39.07** ALA Members are prohibited from securing floor time for non-ALA Member camp sanction request.
- 39.08** Alberta Lacrosse Association sanction will only be available for ALA Members who are in good standing and for partner programs of the ALA who adhere to the ALA Code of Conduct.
- 39.09** The camp sanction fee for the year will be \$200 per camp.
- 39.10** The ALA will communicate only ALA sanctioned camps to the ALA Membership.

REGULATION 40– REGULATION REVISIONS

- 40.01** Revision to ALA Regulations may not be made from March 1 to August 31 in any given year.